



Grants received from Government and non-governmental agencies for research projects, endowments, Chairs in the institution during the last five years

NAAC - 2021

KARNATAKA STATE COUNCIL FOR SCIENCE AND TECHNOLOGY

Indian Institute of Science Campus, Bengaluru – 560 012

Website: <http://www.kscst.iisc.ernet.in/spp.html> || Email: spp@kscst.iisc.ernet.in || Phone: 080-23600978

43rd Series of Student Project Programme: 2019-20

LIST OF PROJECTS SANCTIONED AND DETAILS OF RELEASE OF SANCTIONED AMOUNT AFTER ONLINE EVALUATION OF PROJECTS

100) NEW HORIZON COLLEGE OF ENGINEERING, BENGALURU

Sl. No.	PROJECT REFERENCE NO.	PROJECT TITLE	BRANCH	DEGREE	NAME OF THE GUIDE(s)	NAME OF THE STUDENTS	SANCTIONED AMOUNT (In Rs.)	STATUS OF PROJECT	BALANCE AMOUNT RELEASED AFTER EVALUATION
561.	43S_BE_0003	THEFT IDENTIFICATION & ALERT THROUGH MOTION DETECTION AND FACIAL RECOGNITION USING IOT	COMPUTER SCIENCE AND ENGINEERING	B.E.	Prof. GAGAN S PURAD	Mr. NASIR HASAN DILAWAR Mr. KRISHNA VINEETH P Mr. NITHINDRA D	5000.00	COMPLETE	2500.00
562.	43S_BE_0030	DESIGN AND DEVLEOPMENT OF VARIABLE FREQUENCY ULTRASONIC PEST REPELLER	ELECTRICAL AND ELECTRONICS ENGINEERING	B.E.	Dr. SUJITHA S	Mr. PIYUSH KUMAR Ms. PREETHI SINHA Ms. LISHA REDDY	3000.00	COMPLETE	1500.00
563.	43S_BE_0046	ARTIFICIAL INTELLIGENCE ENABLED COOLANT MONITORING SYSTEM	MECHANICAL ENGINEERING	B.E.	Dr. NAGENDRA J	Mr. SHIVAPRASAD S Mr. SAMMED PATIL Mr. SHREEKRISHNA Mr. SRIVATHSA S	5500.00	INCOMPLETE	NIL
564.	43S_BE_0053	FABRICATION OF NANO FILTERED BASED EXHAUST SYSTEM TO REDUCE EMISSION IN TWO WHEELERS	MECHANICAL ENGINEERING	B.E.	Dr. MANJUNATHA G.	Mr. TEJAS NANDAN Mr. KAMALESH MAHATO Mr. KAUSHIK KUJUR Mr. RAM BIKASH MANDAL	6000.00	INCOMPLETE	NIL
565.	43S_BE_0065	DESIGN AND FABRICATION OF SOLAR POWERED LOW ALTITUDE SHORT ENDURANCE DRONE	MECHANICAL ENGINEERING	B.E.	Dr. M.S. GANESHA PRASAD	Mr. P. SAI SRI RAJ Mr. RAGHAV V RAO Mr. MAHITESH GOWD Mr. APPU R KRISHNAN	6000.00	INCOMPLETE	NIL
566.	43S_BE_2692	SSWWTS-7 A COST EFFECTIVE GREEN APPROACH FOR WASTEWATER TREATMENT	BIOTECHNOLOGY	B.E.	Dr. H ANANDA VARDHAN Dr. AHSA B M	Ms. SHILADITYA BANERJEE Ms. SINCHAN HAIT	6500.00	COMPLETE	3250.00
567.	43S_BE_2699	ಮಾನಸಿಕ ಆರೋಗ್ಯ: CHATBOT FOR MONITORING MENTAL HEALTH	INFORMATION SCIENCE AND ENGINEERING	B.E.	Dr. R J ANANDHI Dr. SARAVANAN	Mr. MANOJ Ms. PRATHYAKSHA SHARMA Ms. SINDHU K S	4500.00	COMPLETE	2250.00
568.	43S_BE_2702	SMART GLASSES FOR VISUALLY CHALLENGED PEOPLE	INFORMATION SCIENCE AND ENGINEERING	B.E.	Dr. P. MANGAYARKARASI	Mr. SUNIL K A Mr. PRAMOD SENCHA N Mr. MUHAMMAD SHAHBAZ KHAN	4500.00	COMPLETE	2250.00

Sl. No.	PROJECT REFERENCE NO.	PROJECT TITLE	BRANCH	DEGREE	NAME OF THE GUIDE(s)	NAME OF THE STUDENTS	SANCTIONED AMOUNT (In Rs.)	STATUS OF PROJECT	BALANCE AMOUNT RELEASED AFTER EVALUATION
569.	43S_BE_2710	ಕೃಷಿ ಕೈಗಾರಿಕಾ ಯಂತ್ರ - "BLUETOOTH EMBEDDED ROBOTIC WITH AGRICULTURE PLOWING, SEEDING AND GRASS CUTTING POWERED BY SOLAR ENERGY	INFORMATION SCIENCE AND ENGINEERING	B.E.	Mrs. A.RAFEGA BEHAM Dr. R.J.ANANDHI	Ms. MANISHA SAMAL Ms. SAKTHI SRIDEVI Ms. ASHA K	4500.00	COMPLETE	2250.00
570.	43S_BE_2713	ಪಾರ್ಶ್ವವಾಯುವಿಗೆ ಧ್ವನಿ: "VOICE FOR PARALYTIC VICTIMS	INFORMATION SCIENCE AND ENGINEERING	B.E.	Dr. R J ANANDHI Mrs. DIVYA K V	Mr. VISHAK J U Mr. AMITESH K N Ms. LAKSHMI K S	4500.00	COMPLETE	2250.00
571.	43S_BE_3960	ADVANCED IoT SOLUTIONS TO MONITOR UNDERPASS WATER LOGGING	ELECTRONICS AND COMMUNICATION ENGINEERING	B.E.	Dr. M. JAYANTHI	Mr. SHRIPAD AITHAL Ms. SINDHU C R Mr. RUSHAB S G Mr. AKSHAY RAO	4000.00	COMPLETE	2000.00
572.	43S_BE_3966	BATTERY TEST RIG AND BATTERY MANAGEMENT SYSTEM FOR RECYCLING LI-ION CELLS FOR AUTOMOBILE BATTERY PACK	AUTOMOBILE ENGINEERING	B.E.	Prof. JAYASHEEL KUMAR K.A.	Mr. HARISH J Mr. ARBAAZ ZAHID H Mr. PRASHANTH REDDY M Mr. ABHISHEK CHOWDARY	5000.00	COMPLETE	2500.00

NEFT TRANSACTION DETAILS OF SPONSORED PROJECTS UNDER 43RD SERIES OF STUDENT PROJECT PROGRAMME

Sl. No.	Name of the College	Total No. of Projects Sanctioned	Total Project Grant Sanctioned (Rs.)	BATCH 1 (Amount released before evaluation)				BATCH 2 (Amount released after evaluation)			
				Project Grant Released (Rs.)	Total No. of Projects Sanctioned	Transaction ID	Transaction Date	Project Grant Released (Rs.)	Total No. of Projects Sanctioned	Transaction ID	Transaction Date
100	NEW HORIZON COLLEGE OF ENGINEERING, BENGALURU	12	59,000	29,500	12	P20060399563665	03-06-2020	20,750	9	P20091852178608	18-09-2020

Dated: 23th May, 2020

To:
The Hon'ble Chairman

F. No.67-18/RFD/GOC/POLICY-1/2018-19
All India Council for Technical Education
(A Statutory body under Ministry of HRD, Govt. of India)
Nelson Mandela Marg, Vasant Kunj, New Delhi-110070 Website: www.aicte-india.org

For Kind Information

Mayurty
1/6/2020

GOC - Sanction Letter for E-Conference

To
The Director/ Principal/ Registrar
New Horizon College of Engineering (E&T),
Ring Road, Near Marathalli, Bellandur Post,
Kudubhisanaahalli, Bangalore Urban, Karnataka-560103

Subject: To organize Conference in online mode i.e. E-Conference under the scheme Grant for Organizing Conference (GOC)-reg.

Sir/ Madam,

With reference to the Sanction Letter No.67-18/RFD/GOC/POLICY-1/2018-19 dated-15.11.2019 and proposal submitted by your institute, this is to convey that an amount of Rs. 5,00,000/- (Rupees Five lakh only) was sanctioned and released to your institute in the month of December-2019 for organizing Conference under the scheme Grant for Organizing Conference (GOC), as per details given below:

1.	Name and address of the Beneficiary Institution:	Director/ Principal/ Registrar New Horizon College of Engineering (E&T), Ring Road, Near Marathalli, Bellandur Post, Kudubhisanaahalli, Bangalore Urban, Karnataka-560103
2.	Permanent ID of Institute:	1-11989651
3.	Title of Conference:	INTERNATIONAL CONFERENCE ON RESEARCH PERSPECTIVES, IOT IN HYBRID GRID INTEGRATED RENEWABLE ENERGY SOURCES
4.	Name of Coordinator:	Dr.MSujitha

The grant was released to the institute's account as per details given in table below:

Institute PAN No.	Bank Name	Bank Branch Name	Bank Branch Address	Account Holder Name	Account Type	Account Number	IFSC Code
AAAT N306 LE	INDIAN BANK	NHCE Branch	Ring Road, Kadubeesanaahalli, Near Marathalli, Bangalore - 560016	New Horizon College of Engineering	Current Account	484700078	IDIB000N112

The grant was released to organize the conference in physical mode, but due to outbreak of COVID-19, the Council has decided to give option to the institutions to organize the conference in online mode only i.e. E-Conference with additional terms and conditions.

Note:

1. If your institute has organized the conference in the stipulated time, then you are intimated to submit the requisite documents along with balance amount, if any.
2. If your institute has not organized the conference after receipt of grant, then you are allowed to organize the conference in online mode i.e. E-Conference within 6 months of receipt of this letter.
3. If your institute does not want to organize the E-conference, then you are required to refund the complete grant along with the interest accrued thereon.
4. The grant from AICTE will be Rs. 50,000 or 1/3rd of the total expenditure incurred for organizing the E-Conference, whichever is lesser. Rest amount is required to be refunded to AICTE.

Changam

Dated: 27th May, 2020

F.No.67-18/RIPD/GOC/POLICY-1/2018-19

- a. Feedback form in the prescribed proforma.
- b. Original Statement of actual Expenditure & Utilization Certificate in the prescribed proforma duly signed by the Head of the institution and countersigned by Registrar/Finance Officer/Govt. Auditor. In case of self-financing/private institutions, Statement of actual Expenditure & Utilization Certificate are required to be audited & signed by a Chartered Accountant (with membership no., full address & stamp). Photocopies of formats are enclosed.
- c. Copy of the proceedings/Project completion report.
- d. Attested photocopies of supporting vouchers/bills of expenditure incurred for Organizing Conference.
- e. Soft copy of photographs of conference.
- f. One video of 1-minute duration mentioning: (i). Introduction of the Coordinator mentioning the name and state of institute. (ii). Conference details and achievements attained through Conference (iii). How the Conference was beneficial to students, faculty and institute? (iv). Thanking message for AICTE support.

VI. General instructions

- a. Any Change in the programme for holding Conference, change of Coordinator name, Venue and Date should be effected with prior approval of the Council, failing which the sanction for the grant already issued would be treated as automatically withdrawn.
- b. The assets-acquired wholly or substantially of the All India Council for Technical Education's grants shall not be disposed or encumbered or utilized for the purposes other than those for which it was given without proper sanction of the Council and should, at any time the Institution ceased to function, such assets shall revert to the All India Council for Technical Education.
- c. The beneficiary institute will make best efforts to promote the scheme by mentioning the sponsorship/support from AICTE, carrying the Logo of AICTE in conference and other means.
- d. The grantee Institution shall observe all financial norms and guidelines as prescribed by the AICTE/ Government of India from time to time. GOI GFR rules ([@https://doe.gov.in/order-circular/general-financial-rules2017-0](https://doe.gov.in/order-circular/general-financial-rules2017-0)) should be followed during utilization of grant.

Yours sincerely,

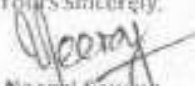
Neeraj Saxena
Advisor (IDC)

Copy forwarded for information and necessary action to:

1. **Name and Address of the Coordinator**
Dr.MSujitha,
New Horizon College of Engineering (E&T),
Ring Road, Near Marathalli, Bellandur Post,
Kudubhisahalli, Bangalore Urban,
Karnataka-560103
2. **Guard File**

The instructions/guidelines to be followed by College/Institution

I. Limit of Funding

- a. The grant from AICTE will be Rs. 50,000 or 1/3rd of the total expenditure incurred for organizing the E-Conference, whichever is lesser.
- b. The balance amount should be immediately refunded to AICTE with interest accrued thereon.

There may be the following expenditure heads under E-Conference:

- a. Certificate/Brochure and other documents designing.
- b. Conference website designing & updating.
- c. Honorarium to Experts/ Resource Persons.
- d. Publication of proceedings.
- e. Miscellaneous.

II. Submission of documents by college/institution to AICTE on receipt of this letter/grant

- a. The Acceptance letter with dates for Organizing E-Conference should reach this office within 15 days from the date of receipt of this Sanction Letter duly signed and sealed by Coordinator and Head of the institution along with permission/clearance of Govt. of India for organizing E-Conference.

III. Maintenance of accounts

- a. The Institute shall strictly follow the provisions laid down in this Letter No. F. No. 67-18/RIFD/GOC/Policy-1/2018-19 dated: 27-05-2020 issued by this office. All correspondence related to the conference must contain this number along with year of sanction of the conference failing which correspondence will not be entertained.
- b. Funds covered by this grant shall be kept separately and would not be mixed up with other funds, so as to know the amount of interest accrued on the grant.
- c. The University/College/Institute shall maintain proper accounts of the expenditure out of the grant.
- d. The Council or its nominee shall have the right to check/verify the account to satisfy that the fund has been utilized for the purpose for it was sanctioned.

IV. Refund of grant to AICTE (by way of a demand draft in favour of Member Secretary, AICTE, New Delhi)

- a. In case the event is cancelled or institute does not want to organize the E-Conference, the fund released should be immediately refunded to AICTE with interest accrued thereon.
- b. The grant shall be refunded to AICTE if the Letter of Approval (LOA) or Extension of Approval is not issued by AICTE to the institute for the academic year 2019-20.
- c. The proposed/approved E-Conference shall be conducted within 6 months from the date of receipt of this letter. If E-conference is not conducted within stipulated time period, the released amount, along with interest accrued thereon, has to be necessarily returned to AICTE within one month, failing which penalty @ 18% will be levied.
- d. Interest accrued on the grant released, shall be refunded to AICTE.
- e. No payment is permissible against the conference already conducted before the receipt of grant. Institutions are liable to refund the grant if received after the conduct of conference and have no plan of conducting the E-conference ahead.
- f. As AICTE needs adequate time for depositing the Demand Draft in the bank, the same be immediately dispatched to avoid any lapse of the validity period.

V. Submission of documents by college/institution to AICTE after conduct of conference

The following documents must be submitted to AICTE within a period of one month, from the date of conduct of Conference:



Phone : 011-26131577 - 78, 80
011-29581000
Website : www.aicte-india.org



सत्यमेव जयते

अखिल भारतीय तकनीकी शिक्षा परिषद्
(भारत सरकार का एक सांविधिक निकाय)
(मानव संसाधन विकास विभाग, भारत सरकार)
नेशनल मंडेला मार्ग, वसन्त कुंज, नई दिल्ली-110070

ALL INDIA COUNCIL FOR TECHNICAL EDUCATION
(A Statutory Body of the Govt. of India)
(Ministry of Human Resource Development, Govt. of India)
Nelson Mandela Marg, Vasant Kunj, New Delhi-110070

Dr. Neeraj Saxena
Adviser (IDC)

F.No.67-18/RIFD/GOC/Policy-1/2018-19
Dated: 07.01.2021

To,

The Principal
New Horizon College of Engineering (E&T),
Ring Road, Near Marathalli, Bellandur-Post,
Kudubhisanaahalli, Bangalore Urban,
Karnataka-560103

Sub: - Extension of time to conduct the Conference in offline mode under GOC Scheme.

Sir,

Reference your letter dated-08.12.2020, requesting permission to organize the Conference in offline mode from 24th to 26th March, 2021. It is to inform that approval is accorded for organizing the Conference on the proposed dates. However, in view of the Covid-19 pandemic, the directions/guidelines of the Central/State Government may be followed in this respect. No further extension will be provided under any circumstances.

The conditions laid in the scheme guidelines are to be strictly complied.

Yours sincerely

(Neeraj Saxena)

Copy forwarded for information and necessary action to:-

1. **Dr. M. Sujitha A.**
(Coordinator)
New Horizon College of Engineering (E&T),
Ring Road, Near Marathalli, Bellandur-Post,
Kudubhisanaahalli, Bangalore Urban,
Karnataka-560103

To:

The HoD-EEE

Dated: 10 May 2019

F. No. 34-55/60/RIFD/FDP/Policy-1/2017-18

All India Council for Technical Education

(A Statutory body under Ministry of HRD, Govt. of India)
Nelson Mandela Marg, Vasant Kunj, New Delhi-110070 Website: www.aicte-india.org



FDP - Sanction Letter

To
The Drawing and Disbursing Officer,
All India Council for Technical Education,
Nelson Mandela Marg,
Vasant Kunj,
New Delhi - 110070

Sub: Release of a sum of Rs 318000/- for conduct of Faculty Development Programme (FDP)- reg

Sir,

This is to convey the sanction of the Council for payment of Rs. 318000/- (Rupees Three Lakh Eighteen Thousand Only) for conduct of FDP on Faculty Development Program on High Performance, Grid and Cloud Computing (HGCC) to NEW HORIZON COLLEGE OF ENGINEERING (M & T), BANGALORE URBAN, Pin No- 560103, Karnataka, under the Scheme of Faculty Development Programme.

1. The amount of the grant shall be drawn by the Drawing and Disbursing Officer, All India Council for Technical Education on the grant-in-aid bill and shall be disbursed to and credited to the Registrar/ Director/Principal of the institute through RTGS.
2. This grant-in-aid is being released in conformity with the terms & conditions as well as norms of the scheme as already communicated, and also being communicated in this letter.
3. The sanctioned amount is debitible to the Major Head 602.6(a) Gen. of the Scheme of Faculty Development Programme and is valid for payment during the financial year 2019-20.

The instructions/guidelines to be followed by University/Institution

1. Release of funds and maintenance of accounts

- a. The Principal of the institute and the Coordinator of the program are requested to verify the correctness of the under mentioned bank account/ RTGS details submitted by them along with the Proposal, in which the grant is being released:

Institute PAN No.	Bank Name	Bank Branch Name	Bank Branch Address	Account Holder Name	Account Type	Account Number	IFSC Code
AAATN3061E	INDIAN BANK	NEW HORIZON COLLEGE OF ENGINEERING	BANGALORE	NEW HORIZON COLLEGE OF ENGINEERING	Current Account	484700078	IDIB000N112

In case of any omission the same should be reported to AICTE immediately

- b. The Institute shall strictly follow the provisions laid down in the scheme document and sanction order no. F. No. 34-55/60/RIFD/FDP/Policy-1/2017-18 dated 10.05.2019 issued by this office.
- c. Funds covered by this grant shall be kept separately and would not be mixed up with other funds so as to know the amount of interest accrued on the grant.
- d. The University/College/Institute shall maintain proper accounts of the expenditure out of the grants, which shall be utilized only on approved items of expenditure.
- e. The grant is intended to cover items of expenditure connected with the Faculty Development Programme such as Boarding & Lodging to the participants, TA to outstation participants, Honorarium to Course Coordinator, reading material to participants, Honorarium to resource persons, TA/DA to resource persons including two outstations resource persons & working expenses (reprographic services, postage, transport, daily wages, tea/coffee etc).

Dated: 18 May 2019

- f. The FDP will be organized for 2 weeks with minimum 40 participants. The approved FDP shall be conducted within nine months from the date of release of funds
- g. Any unavoidable circumstantial change in the Program with respect to name of Project Coordinator, Venue and date for organizing FDP would mandatorily require prior approval of the Council. All such requests should be addressed to AICTE, in advance, recording the specific reasons for proposed changes, failing which the offer for the grant already issued would be treated as automatically withdrawn and the financial assistance released in favour of the beneficiary institution shall be refunded immediately to the Council. Kindly mention the File No. 34-55/____/RIFD/FDP/Policy-1/2017-18 in your future correspondence.
- h. Program Evaluation Committee (PEC) is required to be constituted at institutional level. The constitution of the PEC shall be as under
- (i) Principal/Director/Registrar of the institution (Chairperson),
 - (ii) Coordinator of the program (Member Secretary),
 - (iii) Two HODs and one subject expert (members)
- The members of the said PEC shall not be below the rank of Associate-Professor. A test shall be conducted by Program Evaluation Committee (PEC) at the end of the program and the certificates shall be issued to those participants who have attended the program and have qualified in the test. The minutes of the meetings, along with PEC report, are to be submitted to the Council at end of the program along with other mandatory documents.
- i. GOI GFR rules (@<https://doe.gov.in/order-circular/general-financial-rules2017-0>) should be followed during utilization of grant.
- j. This Sanction Order may be treated as Offer Letter for all purposes.

Yours sincerely,

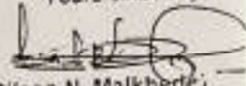
 (Dileep N. Malkher)

Advisor-I (RIFD)

28/6/19

Copy forwarded for information and necessary action to: -

1. Coordinator of the Program

Dr. ASHA V
 NEW HORIZON COLLEGE OF ENGINEERING (M & T)
 RING ROAD, NEAR MARATHALLI,
 KADUBHISANAHALLI,
 BELLANDUR POST BANGALORE URBAN
 BANGALORE - 560103

2. The Registrar / Director / Principal

NEW HORIZON COLLEGE OF ENGINEERING (M & T)
 RING ROAD, NEAR MARATHALLI,
 KADUBHISANAHALLI,
 BELLANDUR POST BANGALORE URBAN
 BANGALORE - 560103

3. Guard File

UTILIZATION CERTIFICATE

GRANT
3.1.2 & 3.2.1

PROGRAM NAME: **FACULTY DEVELOPMENT PROGRAMME**
 AQIS Application ID: **1-3564173860**
 Project Title: **"HIGH PERFORMANCE, GRID AND CLOUD COMPUTING (HGCC)"**

Sl No.	Details	Amount
1	Previous Year balance (Opening Balance (OB), if any)	NIL
2	Grants Sanctioned	7,00,000.00
3	Actual Grants Received	3,18,000.00
4	Balance yet to be received (2-3)	3,82,000.00
5	Cheque No.& Date / RTGS dt : 17-07-2019	
6	Bank Interest (if any)	NIL
7	Total available grants (3+4)	7,00,000.00
8	Actual Grants utilized (Statement of Expenditure enclosed)	7,59,369.00
9	Unspent Balance (8-7)	0.00
10	Excess Expenditure supported by Management	59,369.00

Certified that Rs.3,18,000/- of grant-in-aid under the program name Faculty Development Program was released by All India Council for Technical Education (AICTE) in favor of New Horizon College of Engineering for the vide letter No.34-55/60/RIFD/FDP/Policy-1/2017-18 dated 10.05.2019 as stated above during the year 2019. The above grant was sanctioned towards FDP Titled **"HIGH PERFORMANCE, GRID AND CLOUD COMPUTING"**. Out of sanctioned grants, a sum of Rs. 7,59,369/- (Rupees Seven Lakhs Fifty Nine Thousands Three hundred and Sixty Nine Only) has been utilized for the purpose of which it was sanctioned and Rs. 3,82,000/- remains yet to be received. Expenditure incurred for the purpose for which the grant was sanctioned is verified with the vouchers produced before me.

Certified that I have satisfied myself that the conditions on which the grant-in-aid was sanctioned have been fulfilled and that I have exercised the following checks to see that the money was actually utilized for the purpose for which it was sanctioned.

V. ASHA
 PROFESSOR & HOD, MCA Dept
 New Horizon College of Engg
 Bangalore - 103.

Signature and Address of
 The Project Coordinator



For I.S. PRASAD & CO.,
 CHARTERED ACCOUNTANTS

Signature with Seal
 Chartered Accountant
 (FRN: & M.No)

Signature of the Head of Institution and Seal
 Principal
 New Horizon College of Engineering
 Bangalore - 103.

Sr. Executive Director - Accounts & Finance

All India Council for Technical Education

(A Statutory body under Ministry of HRD, Govt. of India)
Nelson Mandela Marg, Vasant Kunj, New Delhi-110070 Website: www.aicte-india.org



STTP- Sanction Letter

Ref. No. 34-65/292/RIFD/STTP/Policy-1/2018-19

Date _____

12/12/2019

To

The Drawing and Disbursing Officer,
All India Council for Technical Education,
Nelson Mandela Marg,
Vasant Kunj, New Delhi - 110070

Sub: Release of grant for conduct of Short Term Training Programme (STTP) under AQIS 2018-19 during the financial year 2019-20- reg.

Sir,

This is to convey the sanction of the Council for payment of **Rs. 250000/- (Rupees Two Lakh Fifty Thousand Only)** for conduct of Short Term Training Program as per details given below:-

1. Name and address of the beneficiary University / Institution.	NEW HORIZON COLLEGE OF ENGINEERING (E&T) . RING ROAD, NEAR MARATHALLI, BELLANDUR POST, KADUBHISANAHALLI BANGALORE URBAN-560103 Karnataka
2. Permanent ID of Institute	1-11989651
3. Institute type	Unaided - Private
4. Name of Coordinator	Dr. SUJITHA S ✓
5. Amount sanctioned	Rs. 250000/-
6. Amount to be released	Rs. 250000/- Full & final payment
7. Head of account	601.15(a) Gen. Short Term Training Programme (Plan)
8. The authorized officer in whose favour Cheque/ Demand Draft/ RTGS is to be made	REGISTRAR / DIRECTOR / PRINCIPAL
9. Title of the programme	IOT IN RENEWABLE ENERGY RESOURCES INTEGRATION TO ELECTRICITY GRID.

1. The amount of the grant shall be drawn by the Drawing and Disbursing Officer, All India Council for Technical Education on the grant-in-aid bill and shall be disbursed to and credited to the Registrar/ Director/Principal of the institute through RTGS.

This grant-in-aid is being released in conformity with the terms & conditions as well as norms of the scheme as already communicated, and also being communicated in this letter.

3. The Principal of the Institute and the Coordinator of the Program are requested to verify the correctness of the under-mentioned Bank Account / RTGS Details submitted by them alongwith the proposals, in which the grant is being released:-

Institute PAN No.	Bank Name	Bank Branch Name	Bank Branch Address	Account Holder Name	Account Type	Account Number	IFSC Code
AAATN3061E	INDIAN BANK	NHCE Branch	Ring Road, Kadubeesanahalli, Near Marathalli, Bangalore - 560016	New Horizon College of Engineering	Current account	484700078	IDIB000N112

Instructions/Guidelines to be followed by the University/Institution

I. Disbursement of funds to University/Institutions

- The full amount of the grant sanctioned is being released as advance to the University/Institute.
- The amount spent by the institute on the conduct of STTP shall be adjusted on the basis of utilization certificate and detailed expenditure statement submitted by the University/Institution on the prescribed format along with other mandatory documents viz feedback form, copy of proceedings and completion report etc.
- The above said amount of grant shall be refunded back to AICTE if the Letter of Approval (LOA) / Extension of Approval (EOA) is not issued by AICTE to the institute for the academic year 2019-20.

II Maintenance of Accounts

- The Institute shall strictly follow the provisions laid down in the scheme document as available on the portal.
- Funds covered by this grant shall be kept separately and would not be mixed up with other funds so as to know the amount of interest accrued on the grant.
- The University/College/Institute shall maintain proper accounts of the expenditure out of the grants, which shall be utilized only on approved items of expenditure.
- The grant is intended to cover items of expenditure connected with the Short Term Training Programme such as Boarding & Lodging to the participants, TA to outstation participants, Honorarium to Course Coordinator, reading material to participants, Honorarium to resource persons, TA/DA to resource persons including two outstations resource persons & working expenses (reprographic services, postage, transport, daily wages, tea/coffee etc).

III. Conduct of test and issuance of certificate

A test shall be conducted by Program Evaluation Committee (PEC) at the end of the program and the certificates shall be issued to those participants who have attended the program and have qualified in the test.

Submission of Documents by the University/Institutions to AICTE

a. The following mandatory relevant documents are required to be submitted by the University/Institution within one month of the completion of the program:-

- (i) Original Statement of actual expenditure & Utilization Certificate in the prescribed proforma duly signed by the Head of the institution and countersigned by Registrar/Finance Officer/Govt. Auditor. In case of self-financing/private institutions, Statement of actual Expenditure & Utilization Certificate are required to be audited & signed and sealed by a Chartered Accountant endorsing the membership number and complete postal address. Format for the same is available on AICTE web portal.

The University/Institution is not required to submit bills/vouchers/invoices etc for the expenditure incurred out of recurring grants. However, such copies of bills/vouchers/invoices shall be digitized by respective institutions receiving grant and uploaded scanned copies of such bills/vouchers/invoices etc on the portal for availability and view at any point of time.

- (ii) Feedback form in the prescribed proforma.
- (iii) Copy of the proceedings and completion report.
- (iv) List of candidates who have successfully completed the program on the basis of the test conducted by Program Evaluation Committee (PEC).
- (v) Report submitted by Program Evaluation Committee (PEC).

b. The amount of the grant shall be adjusted on submission of utilization certificate & detailed expenditure statement by University/Institution. On receipt of these documents, the total amount of financial assistance, admissible as per the norms, shall be worked out and grant-in-aid adjusted.

V. General instructions

- a. Preferably 10% of the participants may be industry professionals deputed by industry. Further, not more than 2 participants shall be from the host institution/group of institutions.
- b. Money to be reimbursed on the grant (for any reasons to include unspent amount, interest, penalty if imposed) shall be refunded back to AICTE in the form of Demand Draft payable to Member Secretary, AICTE, New Delhi.
- c. As AICTE needs adequate time for depositing the Demand Draft in the bank, the same be immediately dispatched to avoid any lapse of the validity period.
- d. The STTP is a residential program of a duration of six days with minimum 40 participants. The approved STTP shall be conducted within three months from the date of release of funds.
- e. If programme is not conducted in the period of three months of the issuance of this Sanction Order, the released amount, alongwith interest accrued thereon, has to be necessarily returned back to AICTE within a month.
- f. The expenditure under the Heads 'Honorarium to Course Coordinator' and 'Honorarium to Resource Persons' shall not exceed 1% & 20% respectively of

the total sanctioned grant for the Programme. However, overall expenditure shall not exceed the funds sanctioned for the Programme.

- g. Any extra money required to complete the programme must be borne by the institute from their own resources. But the quality of the activities should not be compromised.
- h. Any unavoidable circumstantial change in the program with respect to name of Project Coordinator, Venue and date for organizing STTP would mandatorily require prior approval of the Council. All such requests should be addressed to AICTE, in advance, recording the specific reasons for proposed changes, failing which the offer for the grant already issued would be treated as automatically withdrawn and the financial assistance released in favour of the beneficiary institution shall be refunded immediately to the Council. Kindly mention the File No. 34-65/292/RIFD/STTP/Policy-1/2018-19 in your future correspondence.
- i. **Program Evaluation Committee (PEC)** is required to be constituted at institutional level. The constitution of the PEC shall be as under:

- (i) Principal/Director/Registrar of the institution (Chairperson).
- (ii) Coordinator of the program (Member Secretary).
- (iii) Two HoDs and one subject expert (members).

The members of the said PEC shall not be below the rank of Associate Professor. A test shall be conducted by Program Evaluation Committee (PEC) at the end of the program and the certificates shall be issued to those participants who have attended the program and have qualified in the test. The minutes of the meetings, along with PEC report, are to be submitted to the Council at end of the program along with other mandatory documents.

- j. **GoI GFR rules** (@<https://doe.gov.in/order-circular/general-financial-rules2017-0>) should be followed during utilization of grant.
- k. This Sanction Order may be treated as Offer Letter for all purposes.

NOTE:- Any deviation from the above will invoke serious action against the Institute.

Yours sincerely,

(Dileep N Malkhed
Advisor-I (RIFI)

1 2 0 5 0 2 0

Copy forwarded for information and necessary action to:-

1. **Name and Address of the Coordinator**
Dr. SUJITHA S
NEW HORIZON COLLEGE OF ENGINEERING (E&T)
RING ROAD, NEAR MARATHALLI, BELLANDUR POST, KADUBHISANAHALLI
BANGALORE 560103 Karnataka
2. **The Registrar / Director / Principal**
NEW HORIZON COLLEGE OF ENGINEERING (E&T)
RING ROAD, NEAR MARATHALLI, BELLANDUR POST, KADUBHISANAHALLI
BANGALORE 560103 Karnataka

All India Council for Technical Education

(A Statutory body under Ministry of HRD, Govt. of India)

Nelson Mandela Marg, Vasant Kunj, New Delhi-110070 Website: www.aicte-india.org



STTP- Sanction Letter

To

The Drawing and Disbursing Officer,
All India Council for Technical Education,
Nelson Mandela Marg,
Vasant Kunj,
New Delhi - 110070

Sub: Release of a sum of Rs. 150000/- for conduct of Short Term Training Programme (STTP) during the financial year 2019-20 - reg.

Sir,

This is to convey the sanction of the Council for payment of Rs. 150000/- (Rupees One Lakh Fifty Thousand only) for conduct of STTP on **THE ROLE OF IOT IN RENEWABLE ENERGY RESOURCES INTEGRATION TO ELECTRICITY GRID**, to **NEW HORIZON COLLEGE OF ENGINEERING (E&T) BANGALORE URBAN** Pin No - 560103 Karnataka, under the Scheme of Short Term Training Programme.

1. The amount of the grant shall be drawn by the Drawing and Disbursing Officer, All India Council for Technical Education on the grant-in-aid bill and shall be disbursed to and credited to the Registrar/ Director/Principal of the institute through RTGS.
2. This grant-in-aid is being released in conformity with the terms & conditions as well as norms of the scheme as already communicated, and also being communicated in this letter.
3. The sanctioned amount is debit to the Major Head 602.13(a) Gen. of the Scheme of Short Term Training Programme and is valid for payment during the financial year 2019-20.

The instructions/guidelines to be followed by University/Institution

I. Release of funds and maintenance of accounts

- a. The Principal of the institute and the Coordinator of the program are requested to verify the correctness of the under mentioned bank account/ RTGS details submitted by them along with the Proposal, in which the grant is being released: -

Institute PAN No.	Bank Name	Bank Branch Name	Bank Branch Address	Account Holder Name	Account Type	Account Number	IFSC Code
AAATN3051E	INDIAN BANK	NEW HORIZON COLLEGE OF ENGINEERING	BENGALURU	NEW HORIZON COLLEGE OF ENGINEERING	Current Account	484700078	IDIB000N112

In case of any omission the same should be reported to AICTE immediately. -

- b. The Institute shall strictly follow the provisions laid down in the scheme document and sanction order no F.No. 34-56/IRFD/STTP/Policy-1/2017-18 dated 10.5.2019 issued by this office.
- c. Funds covered by this grant shall be kept separately and would not be mixed up with other funds so as to know the amount of interest accrued on the grant.
- d. The University/College/institute shall maintain proper accounts of the expenditure out of the grants, which shall be utilized only on approved items of expenditure.
- e. The grant is intended to cover items of expenditure connected with the Short Term Training Programme such as Boparding & Lodging to the participants, TA in outstation participants, Honorarium to Course

Coordinator, reading material to participants, Honorarium to resource persons, TA/DA to resource persons including two outstations resource persons & working expenses (reprographic services, postage, transport, daily wages, tea/coffee etc.

1. The grant is subject to the adjustment on the basis of Utilization Certificate in the prescribed proforma submitted by the University/College/Institution. Further, the accounts of the institute will be open for test check by the Council or Controller & Auditor General of India or any other officer designated by them.

II. Disbursement of funds to University/Institutions

- a. The full amount of the grant sanctioned is being released as advance to the University/Institute.
- b. The amount spent by the institute on the conduct of STTP shall be adjusted on the basis of utilization certificate and detailed expenditure statement submitted by the University/Institution on the prescribed format along with other mandatory documents viz feedback form, copy of proceedings and completion report etc.
- c. The above said amount of grant shall be released on the basis of the Letter of Approval (LOA) issued by AICTE to the institute for the academic year 2019-20.

III. Conduct of test and issuance of certificate

A test shall be conducted by Program Evaluation Committee (PEC) at the end of the program and the certificates shall be issued to those participants who have attended the program and have qualified in the test.

IV. Submission of documents by University/Institution

- a. The following mandatory relevant documents are required to be submitted by the university/institution within one month of the completion of the program -
 - (i) Original Statement of actual expenditure & Utilization Certificate in the prescribed proforma duly signed by the Head of the institution and countersigned by Registrar/Finance Officer/Govt Auditor. In case of self-financing/private institutions, Statement of actual Expenditure & Utilization Certificate are required to be audited & signed and sealed by a Chartered Accountant endorsing the membership number and complete postal address. Photocopies of formats are enclosed.
 - The university/institution is not required to submit bills/vouchers/invoices etc for the expenditure incurred out of recurring grants. However, such copies of bills/vouchers/invoices shall be digitized by respective institutions receiving grant and uploaded scanned copies of such bills/vouchers/invoices etc on the portal for availability and view at any point of time.
 - (ii) Feedback form in the prescribed proforma.
 - (iii) Copy of the proceedings and completion report.
 - (iv) List of candidates who have successfully completed the program on the basis of the test conducted by Program Evaluation Committee (PEC).
 - (v) Report submitted by Program Evaluation Committee (PEC).
- b. The amount of the grant shall be adjusted on submission of utilization certificate & detailed expenditure statement by University/Institution. On receipt of these documents, the total amount of financial assistance, admissible as per the norms, shall be worked out and grant-in-aid adjusted.
- c. The university/institution is expected to submit the above said mandatory documents viz Utilization Certificate, Expenditure Statement and feedback form etc within one month of conduct of STTP. However, delay of further 2 months may be condoned by AICTE in special circumstances as explained by the institute. Delay in submission of documents after three months of the conduct of STTP shall invite a penalty of 10% of the total sanctioned amount of the STTP, to be recovered from the University/Institute. The entire amount of grant already released, along with interest accrued thereon, shall be refunded to AICTE if mandatory documents are not submitted by the University/Institute beyond one year.

V. General instructions

- a. Preferably 10% of the participants may be industry professionals deputed by industry. Further, not more than 20% participants shall be from the host institution/group of institutions.
- b. Interest, accrued on the grant released shall be refunded back to AICTE.
- c. If programme is not conducted in the period of nine months of the issuance of this Sanction Order,

the released amount, along with interest accrued thereon, has to be returned back to AICTE,

- d. The expenditure under the Heads 'Honorarium to Course Coordinator' and 'Honorarium to Resource Persons' shall not exceed 1% & 20% respectively of the total sanctioned grant for the Programme. However, overall expenditure shall not exceed the funds sanctioned for the Programme
- e. Any extra money required to complete the programme must be borne by the institute from their own resources. But the quality of the activities should not be compromised.
- f. The STTP is a residential program of a duration of six days with minimum 40 participants. The approved STTP shall be conducted within nine months from the date of release of funds.
- g. Any unavoidable circumstantial change in the program with respect to name of Project Coordinator, Venue and date for organizing STTP would mandatorily require prior approval of the Council. All such requests should be addressed to AICTE, in advance, recording the specific reasons for proposed changes, failing which the offer for the grant already issued would be treated as automatically withdrawn and the financial assistance released in favour of the beneficiary institution shall be refunded immediately to the Council. Kindly mention the File No. 34-56/⁷⁶/RIFD/STTP/Policy-1/2017-18 in your future correspondence.
- h. Program Evaluation Committee (PEC) is required to be constituted at institutional level. The constitution of the PEC shall be as under:
 - (i) Principal/Director/Registrar of the institution (Chairperson)
 - (ii) Coordinator of the program (Member Secretary),
 - (iii) Two HoDs and one subject expert (members).

The members of the said PEC shall not be below the rank of Associate Professor. A test shall be conducted by Program Evaluation Committee (PEC) at the end of the program and the certificates shall be issued to those participants who have attended the program and have qualified in the test. The minutes of the meetings, along with PEC report, are to be submitted to the Council at end of the program along with other mandatory documents.

- i. Gov GFR rules (@<https://doe.gov.in/order-circular/general-financial-rules2017-0>) should be followed during utilization of grant.
- j. This Sanction Order may be treated as Offer Letter for all purposes.

Yours sincerely,

(Dileep N Malkhede)
Advisor-I (RIFD)

Copy forwarded for information and necessary action to:-

1. Name and Address of the Coordinator
Dr. SUJITHA S.
NEW HORIZON COLLEGE OF ENGINEERING (E&T)
RING ROAD, NEAR MARATHALLI, BELLANDUR POST,
KADUBHISANAHALLI, BANGALORE URBAN
BANGALORE- 560103
2. The Registrar / Director / Principal
Dr. MANJUNATHA
NEW HORIZON COLLEGE OF ENGINEERING (E&T)
RING ROAD, NEAR MARATHALLI, BELLANDUR POST,
KADUBHISANAHALLI, BANGALORE URBAN
BANGALORE- 560103
3. Guard File



Visvesvaraya Technological University

"Jnana Sangama", Belgaum - 590 018, Karnataka State

Dr. H.N. Jagannatha Reddy, BE,ME,Ph.D
REGISTRAR

Phone : (0831) 2405468
Fax : (0831) 2405467

Ref. No:VTU/Aca/2018-19/ 1884/62

Date: 4 JUN 2018

To,
The Principal
New Horizon College of Engineering, Bangalore

Sir/Madam,

Sub: Sanction of Financial Assistance to the selected projects of UG students of your Institution

Ref: VTU/Aca/2017-18/9702, dtd: 18th January 2018

With reference to the above subject, please find herewith a D.D Bearing No 636179, Dated 25-May-18 of Rs. 80,000 towards the sanction of Financial Assistance to the selected projects of UG students. You are requested to give the amount to the concerned students and obtain an acknowledgement for the same.

The students' receipt of acknowledgement should be sent to the undersigned on or before 15-6-2018.

Yours faithfully

REGISTRAR

Encl: as above

To: The Director - Finance

Please do the needful
May 2018

To: The Registrar - Copy

भारतीय स्टेट बैंक
State Bank of India
Drawing Branch: VTU CAMPUS MATCHE
कोड नं. / CODE No: 40649
Tel. No. 0831-2412300

Key: VAFDEY
Sr. No: 48376

2 5 0 5 2 0 1 8
D D M M Y Y Y Y

मांगवापट
DEMAND DRAFT

मांगे जानेपर PRINCIPAL NEW HORIZON COLLEGE OF ENGINEERING*****

या उनके आदेश पर 8

ON DEMAND PAY

OR ORDER 7

रुपये RUPEES Eighty Thousand Only

अदा करें ₹ 80000.00

IOI 000473636179 Key: VAFDEY

Sr. No: 48376

AMOUNT BELOW 80000 (8/5)

मूल्य प्राप्त / VALUE RECEIVED

भारतीय स्टेट बैंक

STATE BANK OF INDIA

अदाकर्ता शाखा / DRAWEE BRANCH: CCPC BANGALURU

कोड नं. / CODE No: 40743

Hitesh Patel
प्रामाणिक इस्ताफ़रकर्ता
HITESH PATEL
S No: 5884

शाखा प्रबंधक
BRANCH MANAGER

कम्प्यूटर द्वारा मुद्रित होने पर ही वैध
VALID ONLY IF COMPUTER PRINTED

केवल 3 महीने के लिए वैध
VALID FOR 3 MONTHS ONLY

₹ 1,50,000/- एवं अधिक मूल्य के दायरे में जारीया द्राफ्ट इस्ताफ़रित होने पर ही वैध है।
INSTRUMENTS FOR ₹ 1,50,000 & ABOVE ARE NOT VALID UNLESS SIGNED BY TWO OFFICERS

⑈636179⑈ 00002000⑈ 000473⑈ 16

ALL INDIA COUNCIL FOR TECHNICAL EDUCATION

Nelson Mandela Marg, Vasant Kunj,
New Delhi-110070,

File No. 58-14/RIFD/Margdarshan/2019-20

6th September, 2019

Margdarshan Sanction Letter

The Drawing and Disbursing Officer
All India Council for Technical Education
Nelson Mandela Marg,
Vasant Kunj, New Delhi-110070,

Sub: Release of Grants under Share & Mentor Institutions (Margdarshan) Scheme during the current financial year 2019-20.

Sir,

This is to convey the sanction of the Council for payment of Rs. 10,00,000/- (Rupees Ten Lakh Only) under the Share & Mentor Institutions (Margdarshan) as Grant-in-aid for meeting the expenditure for implementing the scheme to improve the quality parameters of Mentee institutes so that over a period of time, the programs of the mentee institutes will get accreditation by NBA.

Details given below:

1.	Name of the Beneficiary Institution University / College / Institute	:	New Horizon College of Engg., Ring Road, Bellandur Post, Near Marathalli, Bangalore 560103
2.	Chief Coordinator's Name.	:	Dr. K. Gopalakrishnan
3.	Grant-in-aid Sanctioned	:	Rs. 20,00,000/-
4.	Amount to be Released during the year 2019-20 (90% for Govt. and 50% for Pvt. Instn.)	:	Rs. 10,00,000/- (Rupees Ten Lakh Only)
5.	Duration	:	3 Years

1. The sanctioned grant-in-aid is debitible to the major Head 602.17 (Share & Mentor Institutions -Margdarshan) & valid for payment during the financial year 2019-20.
2. The amount of grant-in-aid shall be drawn by the Drawing and Disbursing Officer (DDO), All India Council for Technical Education, New Delhi on the Grants-in-aid bill and shall be disbursed to and credited to the account of Principal/Director/Registrar New Horizon College of Engg., Ring Road, Bellandur Post, Near Marathalli, Bangalore 560103 through RTGS.
3. The Principal of the institute and the coordinator of the project are requested to verify the correctness of the under mentioned bank account/RTGS details submitted by them along with the proposal, in which the grant is being released:

Institute PAN Number	Bank Name	Bank Branch Name	Bank Branch Address	Account Holder Name	Account Type	Account Number	IFSC Code
AAATN3061E	Indian Bank	New Horizon College of Engineering Branch	Outer ring Road, Kadubishanah all, Bangalore-560103	New Horizon College of Engineering	Current	484700078	IDIB000N112

In case of any omission the same should be reported to AICTE immediately.

The instructions/guidelines to be followed by the institute:

I. Financial Guidelines

1. The date of release of the grant by AICTE shall be taken as the date of commencement of the scheme. The Principal/Director/Registrar shall intimate within 10 days by post (not on e-mail) about the receipt of the grant to AICTE, alongwith acceptance of the instructions/guidelines of the Sanction order to the following address.

Adviser (RIFD)

**All India Council for Technical Education,
Nelson Mandela Marg, Vasant Kunj,
New Delhi-110070**

2. Any expenditure incurred prior to issuance of the sanction order is not allowed to be adjusted in the grant.
3. If the University/Institution do not take the project work within 3 months of the receipt of the grant, approval shall *ipso facto* lapse and the released amount, alongwith interest accrued thereon, has to be returned to AICTE, by way of a demand draft in favor of **Member Secretary, AICTE, New Delhi.**
4. As AICTE needs adequate time for depositing the demand draft in the bank, the same be immediately dispatched to avoid any lapse of the validity period.

II. Scheme Implementation

1. The Mentor Institute shall identify atleast ten other AICTE approved institutions which are yet to get NBA accreditation and are free from vigilance/disciplinary angle as Mentee institutes for the programme. The objective is to help mentee institutes to improve their quality parameters to enable them to get accreditation by NBA.
2. The Mentor institute will provide the list of institutes to which it will provide mentorship and the consent letters with copies of MoUs signed with the mentee institutes. It may be ensured that the mentee institutes are not being mentored by any other mentor institute or by a Margadarshak. Action will be taken if these guidelines are not adhered to. The mentor - mentee mapping is to build a strong linkage so that the outcome of the mentoring results in accreditation of the programs of mentee institutes by NBA.
3. The Mentor Institute should conduct at least 06 FDP of one-week duration each with minimum 30 participants including at least 25 guest lecturers. The distance between mentor-mentee should be less than 200 Kms. **Not to incur expenditure on computer, laptops etc.**

III. Maintenance of accounts by the institute

1. The Mentor Institute shall maintain proper accounts of the Expenditure out of the grants and shall be utilized only on approved items of expenditure. The institute is required to open a separate bank account or to maintain separate account register to get the interest on accumulation of this grant/fund received from AICTE. The interest accrued on the sanctioned grant-in-aid will be reported back to AICTE and refunded to AICTE and not to be adjusted against subsequent installments.
2. Any expenditure above the sanctioned amount of grant is to be incurred from institutes own funds.
3. The institute/University shall not charge any overheads on this Project and will provide all the administrative support for completion of the Project.

4. The grantee shall maintain an audited record of expenditure out of the grant-in-aid and a register for assets, if any, shall be maintained by the Institute in the prescribed form i.e. GFR-19.
5. The accounts of the grantee will be opened for test check by the Council or Comptroller & Auditor General of India or by any officer designated by them.
6. The assets, if any acquired wholly or substantially out of All India Council for Technical Education's grant shall not be disposed or encumbered or utilized for the purpose other than those for which the Grant was given without proper sanction of the All India Council for Technical Education.

IV. Submission of mandatory documents by the institute

1. The Annual Progress Report in the prescribed format along with Statement of Expenditure and Audited Utilization Certificate shall be submitted to AICTE not later than one month after completion of each financial year.
2. **Performance Monitoring Committee (PMC)** is required to be constituted at institutional level. The constitution of the PEC shall be as under:
 - i. Principal/Director of the institution (Chairperson)
 - ii. Two HODs from institute (Members)
 - iii. In case of private institute, one expert from Government institute, not below the rank of Associate Professor (Member)
 - iv. Coordinator of the project (Member Secretary)
3. Scheme Completion Report (SCR) in the prescribed format along with the Audited Statement of Expenditure indicating expenditure incurred in the total duration of the scheme in the prescribed format, utilization Certificate and GFR-19 shall be submitted to the Council in the prescribed format.
4. The Utilization Certificate (UC) supported by Audited Statement of Expenditure to the effect that the grant has been utilized for the purpose for which it has been sanctioned shall be furnished to the All India Council for Technical Education as early as possible after completion of the scheme. It should contain the head-wise break up of expenditure alongwith bills/vouchers duly signed and stamped by the Chief coordinator and head of institute, made from the grant-in-aid provided by the Council.
5. A complete status report of the scheme indicating the achievement of the objectives of the scheme is to be submitted. The report is to include details of activities undertaken by Margdarshan institute for enhancement of quality, attainment of outcomes, self-assessment report (SAR), evaluation report and accreditation certificates of programs of mentee institutes. The number of institutes benefited, FDP and guest lecture photographs of participants, together with their views is to be submitted.
6. The balance amount of the grant will be reimbursed to the mentor institutes only on submission of the mandatory documents. On receipt of these document, total amount of balance of grant, admissible as per the norms, shall be worked out and grant -in-aid shall be released, as 2nd installment, in favor of the Margdarshan Institution.
7. Delay in submission of documents after three months of the completion of the Margdarshan project shall invite a penalty of 10% of the total sanctioned amount of the Margdarshan project, to be deducted from the balance amount of 2nd installment. The entire amount of grant already released, alongwith interest

accrued thereon shall be refunded to AICTE, if mandatory documents are not submitted by the institute beyond one year.

V. General instructions

1. The duration of the scheme is for three years from the date of release of grant. The mentor institute is required to design the activities in such a way that within this period the objective of the scheme is achieved. It may be ensured that the scheme is completed within the stipulated time. If the scheme is not completed in time, no further extension will be granted in any case and institute has to refund the entire amount to AICTE. The request of reimbursement of 50% of remaining amount in case of private institution and 10% in case of Govt. institution shall be made with UC and other related documents in such a way that the entire Margdarshan scheme is completed in the prescribed period of three years.
2. Any unavoidable circumstances change in the Margdarshan scheme with respect to name of coordinator for the Margdarshan scheme would mandatorily require prior approval of the council. All such requests should be addressed to AICTE in advance, recording the specific reasons for proposed change, failing which the offer for the grant already issued would be treated as automatically withdrawn and the grant released in favor of the Margdarshan institution shall be refunded immediately to the Council. Kindly mention the file number 58-14/RIFD/Margdarshan/2019-20 in all future correspondence.
3. The Mentor institute is required to follow all terms & condition laid down in the scheme as well as in the offer letter rigidly.
4. GoI, GFR rules should be followed during utilization of grant.

Yours sincerely,

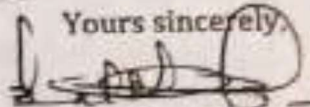
(Dileep N. Malkhede)
Advisor (RIFD)

6/9/19

Copy forwarded for information and necessary action to:

1. **The Principal/Director/Registrar**
New Horizon College of Engg.,
Ring Road, Bellandur Post, Near Marathalli,
Bangalore 560103
2. **Dr. K. Gopalakrishnan, Chief Coordinator,**
New Horizon College of Engg., Ring Road,
Bellandur Post, Near Marathalli,
Bangalore 560103
3. **Office of Director General of Audit**
General Revenues, AGCR Building
I.P. State, New Delhi-110002
4. **Guard File**



PRERANA - Sanction Letter

To
The Drawing and Disbursing Officer,
All India Council for Technical
Education, Nelson Mandela Marg,
Vasant Kunj,
New Delhi - 110070

Sub: Release of a sum of Rs. 651667/- (**Rupees Six Lakh FiftyOne Thousand Six Hundred SixtySeven Only**) being the **Grant-in-Aid** under the scheme **Prerana** for the year 2018-19 payable during the current financial year 2019-20-
reg.

Sir,
With reference to the proposal submitted by the institute, this is to convey that the sanction of the Council for payment of Rs. 651667/- (**Rupees Six Lakh FiftyOne Thousand Six Hundred SixtySeven Only**) as 100% recurring grant Grant-in-Aid under the **PRERANA** scheme, as per details given below:

1.	Name and address of the Beneficiary Institution:	NEW HORIZON COLLEGE OF ENGINEERING (E&T), RING ROAD, NEAR MARATHALLI, BELLANDUR POST, KADURHISANAHALLI, BANGALORE-560101 BANGALORE URBAN, Karnataka
2.	Duration of the scheme:	2 Years
3.	Total Grant-in-aid Sanctioned:	Rs. 651667/-
4.	Amount to be released during the year 2019-20:	Rs. 651667/-
5.	Sanctioned grant-in-aid is debitable to:	Major Head 601.8 (b) & (c)

2. The amount of the Grant shall be drawn by the Drawing and Disbursing Officer, All India Council for Technical Education on the Grant-in-Aid bill and shall be disbursed to and credited to the account of Director/Principal/ Registrar of the institute through RTGS/PFMS.
4. This Grant-in-Aid is being released in conformity with the terms & conditions as well as norms of the scheme as already communicated, and also being communicated in this letter.

The instructions/guidelines to be followed by University/Institution

1. Release of funds

- a. The Principal/ Director of the institute and the Coordinator of the project are hereby requested to verify the correctness of the under mentioned bank account/ RTGS details submitted by them along with the proposal, in which the grant is being released:

Institute PAN No.	Bank Name	Bank Branch Name	Bank Branch Address	Account Holder Name	Account Type	Account Number	IFSC Code
AAATN3061E	INDIAN BANK	NHCE Branch	Ring Road, Kadubesanahalli, Near Marathalli, Bangalore - 560016	New Horizon College of Engineering	Current Account	484700078	IDIB000N112

In case of any omission the same should be reported to AICTE immediately.

- b. The sanction is issued in exercise of the powers delegated to the council and other terms & conditions laid down in the guidelines of the scheme.
- c. 100% Recurring amount as grant-in-aid is being released to AICTE approved institutions under the scheme. There is no non-recurring amount.

Maintenance of accounts

- a. The Institute shall strictly follow the provisions laid down in the scheme document and sanction order No. F.No.72-3/K/ED/Prerana/Policy-1/2018-19 dated _____ 2019 issued by this office. All correspondences related to the scheme must contain this number along with year of sanction of the scheme. Biling which correspondence will not be entertained.
- b. Funds covered by this grant shall be kept separately and would not be mixed up with other funds, so as to know the amount of interest accrued on the grant.
- c. The College/Institute shall maintain proper accounts of the expenditure out of the grants, which shall be utilized only on the scheme.
- d. The Council or its nominee shall have the right to check/verify the account to satisfy that the fund has been utilized for the purpose for it was sanctioned.
- e. The date of release of the grant by AICTE shall be taken as the date of commencement of the scheme. The Principal / Director / Registrar shall intimate about the receipt of the grant to AICTE. Any expenditure incurred prior to the issuance of the approval letter will not be allowed to be adjusted in the grant and if the Institution do not take the scheme work within six month of the receipt of the grant, the approval shall ipso facto lapse.
- f. The amount of interest accrued on the grant should be treated as part of the grant to be utilized for that particular scheme. However, the interest amount accrued along with grant disbursed should not exceed the total grant sanctioned for the scheme. The Institute receiving the grant should reflect the same in the audited statement of accounts/ utilization certificate and may either refund the interest amount to AICTE.
- g. After receipt of the grant from AICTE, the Institute shall send a confirmation to AICTE within 2 months of receipt of grant that the sanctioned scheme has been started/is in progress.
- h. The grant is intended to cover items of expenditure connected with the Prerana Scheme such as Honorarium to the eminent faculty members invited for conducting sessions @ Rs. 2000/- per class of minimum 2 Hours. No TA/DA will be paid. Students will be paid the application fee for such exams through this scheme.

III. Instructions for Implementation of scheme

- e. The parent institution shall provide adequate space for conducting the classes for SC/ST students.
- f. For smooth functioning of scheme and to meet its objectives effectively, it is essential to assign an adequate man power in the form of dedicated faculty as Principal Coordinator and support staff.
- g. The Principal Coordinator shall devise a feed-back mechanism to assess the importance of the programme. The feedback shall be obtained after each programme from each of the SC/ST students. If need be, the centre can update its course curriculum of these programmes.
- h. Any extra money required to complete the programme must be borne by the institute from their own resources. But the quality of the activities should not be compromised.

IV. Refund of grant (by way of a demand draft in favour of Member Secretary, AICTE, New Delhi)

- a. In any case, if the institute is required to refund the grant or interest accrued thereon or balance amount, the amount will be refunded to AICTE.
- b. If the college/institute does not have the Letter of Approval (LOA) or Extension of Approval issued by AICTE for the academic year 2019-20, the fund released should be immediately refunded to AICTE with interest accrued thereon.
- c. If scheme is not started within six months of the issuance of this Offer Letter, the released amount, along with interest accrued thereon, has to be necessarily returned to AICTE.
- d. It may be ensured that the scheme is completed within the stipulated time. If the scheme is not completed in time no further extension will be granted in any case and institute has to refund the entire amount to AICTE.
- e. As AICTE needs adequate time for depositing the Demand Draft in the bank, the same be immediately dispatched to avoid any lapse of the validity period.

V. Submission of documents by college/institution after completion of Scheme/Subsequent years.

The following mandatory relevant documents are required to be submitted by the college/institution within one month of the completion of the scheme:-

- a. Feedback form in the prescribed proforma.

Original Statement of actual expenditure in the prescribed proforma duly signed by the Head of the institution and countersigned by Registrar/Finance Officer/Govt. Auditor. Note: The institution is not required to submit bills/ vouchers/ invoices etc for the expenditure incurred out of recurring grants. However, such copies of bills/ vouchers/ invoices shall be digitized by respective institutions receiving grant and uploaded scanned copies of such bills/vouchers/invoices etc on the portal for availability and view at any point of time.

- c. The Utilization Certificate (UC) supported by Audited Statement of Expenditure to the effect that the grant has been utilized for the purpose for which it has been sanctioned shall be furnished to the AICTE immediately after completion of the scheme. It should contain the head-wise break up of expenditure made from the grant-in-aid provided by the Council. Audited Statement of Expenditure indicating expenditure incurred in the total duration of the scheme in the prescribed format and GFR-19 shall be submitted to the Council.
- d. In case of self-financing/private institutions, Statement of actual Expenditure & Utilization Certificate are required to be audited & signed by a Chartered Accountant (with membership no., full address & stamp). Photocopies of format are enclosed.
- e. Program Evaluation Committee (PEC) is required to be constituted at Institutional level. The constitution of the PEC shall be as under:
 - (i) Principal/Director/Registrar of the Institution (Chairperson)
 - (ii) Coordinator of the scheme (Member Secretary)
 - (iii) Two HODs and one subject expert (Members)

The members of the said PEC shall not be below the rank of Associate Professor. The minutes of the meetings are to be submitted to the Council at end of the scheme along with other mandatory documents.

- f. Project completion report indicating the activities undertaken, number of students benefited, photographs of students together with their views is to be submitted.

V. General instructions

- a. The approved project under Prerana Scheme shall be started within six months from the date of release of funds.
- f. If programme is not started in the period of six months of the issuance of this Sanction Order, the released amount, along with interest accrued thereon, has to be returned back to AICTE. Kindly mention the File No. 72-3/RIFD/Prerana/Policy-1/2018-19 in your future correspondence.
- g. The grantee Institution shall observe all financial norms and guidelines as prescribed by the AICTE/ Government of India from time to time. GOI GFR rules ([@https://doi.gov.in/order-circular/general-financial-rules2017-0](https://doi.gov.in/order-circular/general-financial-rules2017-0)) should be followed during utilization of grant.
- h. This Sanction Order may be treated as Offer Letter for all purposes.

Yours sincerely,

Dilip N. Malhotra
Advisor (RIFD)

Copy forwarded for information and necessary action to:

1. Name and Address of the Coordinator
Dr. ANANDHI JAYADHARMARAJAN,
NEW HORIZON COLLEGE OF ENGINEERING (E&T),
RING ROAD, NEAR MARATHALLI, BELLANDUR POST, KADUBIRISANAHALLI,
BANGALORE-560103, BANGALORE URBAN,
Karnataka
2. The Registrar / Director / Principal
NEW HORIZON COLLEGE OF ENGINEERING (E&T),
RING ROAD, NEAR MARATHALLI, BELLANDUR POST, KADUBIRISANAHALLI,
BANGALORE-560103, BANGALORE URBAN,
Karnataka
3. Guard File

All India Council for Technical Education
(A Statutory body under Ministry of HAD, Govt. of India)
Nelson Mandela Marg, Vasant Kunj, New Delhi-110070 Website: www.aicte-india.org



GOC - Sanction Letter

To

The Drawing and Disbursing Officer
All India Council for Technical Education
Nelson Mandela Marg, Vasant Kunj,
New Delhi-110070

To: Dr. Sujitha

Please do the
needful
Mays

Subject: Release of a sum of Rs. 5,00,000/- (Rupees Five lakh only) as Grant-in-Aid to conduct Conference under the scheme Grant for Organizing Conference (GOC) for the year 2018-19 payable during the current financial year 2019-20-reg.

Sir,

With reference to the proposal submitted by the institute, this is to convey the sanction of the Council for payment of Rs. 5,00,000/- (Rupees Five lakh only) to conduct Conference under the scheme Grant for Organizing Conference (GOC) as per details given below:

1. Name and address of the Beneficiary Institution:	Director/ Principal/ Registrar New Horizon College of Engineering (E&T), Ring Road, Near Marathalli, Bellandur Post, Kudubhisanahalli, Bangalore Urban, Karnataka-560103
2. Permanent ID of Institute:	1-11969651
3. Title of Conference:	INTERNATIONAL CONFERENCE ON RESEARCH PERSPECTIVES: IOT IN HYBRID GRID INTEGRATED RENEWABLE ENERGY SOURCES
4. Name of Coordinator:	Dr.MSujitha
5. Grant-in-aid Sanctioned:	Rs. 5,00,000/- (Rupees Five lakh only)
6. Amount to be released during the year 2019-20:	Rs. 5,00,000/- (Rupees Five lakh only)
7. Sanctioned grant-in-aid is debitable to:	Major Head 601.17 (a) Gen (GOC) Plan Head

- The amount of the Grant shall be drawn by the Drawing and Disbursing Officer, All India Council for Technical Education, New Delhi on the Grant-in-aid bill and shall be disbursed to and credited to the account of Registrar/Director/Principal of the institute through RTGS.
- This grant-in-aid is being released in conformity with the terms & conditions as well as norms of the scheme as already communicated and also being communicated in this letter.

The instructions/guidelines to be followed by College/Institution

1. Release of funds

- The Principal/Director of the institute and the Coordinator of the program are hereby requested to verify the correctness of the undermentioned bank account/ RTGS details submitted by them alongwith the Proposal/Estimated expenditure details, against which the grant is being released:

Institute PAN No.	Bank Name	Bank Branch Name	Bank Branch Address	Account Holder Name	Account Type	Account Number	IFSC Code
AAATN 3061E	INDIAN BANK	NHCE Branch, Bangalore	Outer Ring Road, Kadubeesanahalli, Bangalore	New Horizon College of Engineering	Current Account	484700078	IDIB000 N112

In case of any omission the same should be reported to AICTE immediately.

- b. The full amount of the grant sanctioned is being released as advance to the College/ Institute.
- c. This sanction is issued in exercise of the powers delegated to the Council and other terms and condition laid down in the guidelines of the scheme.

II. Limit of Funding

- a. The total required fund of Rs. 15 Lakhs for organizing conference will be Rs. 10 Lakhs contributed by the Institute and the remaining Rs. 5 Lakhs shall be granted by the AICTE.
- b. However, the grant from AICTE will be Rs. 5 Lakhs or 1/3rd of the total expenditure incurred for organizing the Conference, whichever is lesser, if expenditure/estimate/ budget for the conference is less than Rs. 15 Lakhs.

III. Submission of documents by college/institution to AICTE on receipt of grant

- a. The Acceptance letter with dates for Organizing Conference should reach this office within 15 days from the date of receipt of this Sanction Letter duly signed and sealed by, Coordinator and Head of the Institutions along with permission/clearance of Govt. of India for Organizing Conference.

IV. Maintenance of accounts

- a. The Institute shall strictly follow the provisions laid down in the scheme document and sanction Letter No. F. No. 67-18/ RIFD/GOC/Policy-1/2018-19 dated: 15.11.2019, issued by this office. All correspondence related to the conference must contain this number along with year of sanction of the conference failing which correspondence will not be entertained.
- b. Funds covered by this grant shall be kept separately and would not be mixed up with other funds, so as to know the amount of interest accrued on the grant.
- c. The University/College/Institute shall maintain proper accounts of the expenditure out of the grant.
- d. The Council or its nominee shall have the right to check/verify the account to satisfy that the fund has been utilized for the purpose for it was sanctioned.

V. Refund of grant to AICTE (by way of a demand draft in favour of Member Secretary, AICTE, New Delhi)

- a. In case the event is cancelled, the fund released should be immediately refunded to AICTE with interest accrued thereon.
- b. The grant shall be refunded to AICTE if the Letter of Approval (LOA) or Extension of Approval is not issued by AICTE to the Institute for the academic year 2019-20.
- c. The proposed/approved Conference shall be conducted within 12 months from the date of receipt of grant. If conference is not conducted within stipulated time period, the released amount, along with interest accrued thereon, has to be necessarily returned to AICTE within one month, failing which penalty @ 18% will be levied.
- d. Interest accrued on the grant released, shall be refunded to AICTE.
- e. No payment is permissible against the conference already conducted before the receipt of AICTE Letter dated-04.06.2019 regarding submission of the "estimated expenditure". Such institutions are liable to refund the grant if have no plan of conducting the conference ahead.
- f. As AICTE needs adequate time for depositing the Demand Draft in the bank, the same be immediately dispatched to avoid any lapse of the validity period.

VI. Submission of documents by college/institution to AICTE after conduct of conference

The following documents must be submitted to AICTE within a period of one month, from the date of conduct of Conference:

- a. Feedback form in the prescribed proforma.

- b. Original Statement of actual Expenditure & Utilization Certificate in the prescribed proforma duly signed by the Head of the institution and countersigned by Registrar/Finance Officer/Govt. Auditor. In case of self-financing/private institutions, Statement of actual Expenditure & Utilization Certificate are required to be audited & signed by a Chartered Accountant (with membership no., full address & stamp). Photocopies of formats are enclosed.
- c. Copy of the proceedings/Project completion report.
- d. Attested photocopies of supporting vouchers/bills of expenditure incurred for Organizing Conferences.
- e. Soft copy of photographs of conference.
- f. One video of 1-minute duration mentioning: (i). Introduction of the Coordinator mentioning the name and state of institute. (ii). Conference details and achievements attained through Conference (iii). How the Conference was beneficial to students, faculty and institute? (iv). Thanking message for AICTE support.

VII. General instructions

- a. Any Change in the programme for holding Conference, change of Coordinator name, Venue and Date should be effected with prior approval of the Council, failing which the sanction for the grant already issued would be treated as automatically withdrawn.
- b. The assets acquired wholly or substantially of the All India Council for Technical Education's grants shall not be disposed or encumbered or utilized for the purposes other than those for which it was given without proper sanction of the Council and should, at any time the institution ceased to function, such assets shall revert to the All India Council for Technical Education.
- c. The beneficiary institute will make best efforts to promote the scheme by mentioning the sponsorship/support from AICTE, carrying the Logo of AICTE in conference and other means.
- d. The grantee institution shall observe all financial norms and guidelines as prescribed by the AICTE/ Government of India from time to time. GOI GFR rules (@<https://doe.gov.in/order-circular/general-financial-rules2017-0>) should be followed during utilization of grant.
- e. This Sanction Letter may be treated as Offer Letter for all purposes.

Yours sincerely

Dileep N. Mallhede
Advisor (RIFD)

22 NOV 2019

Copy forwarded for information and necessary action to:

1. Name and Address of the Coordinator
Dr. Sujitha A.
New Horizon College of Engineering (E&T),
Ring Road, Near Marathalli, Bellandur Post,
Kudubhisanaahalli, Bangalore Urban,
Karnataka-560103
2. The Registrar / Director / Principal
New Horizon College of Engineering (E&T),
Ring Road, Near Marathalli, Bellandur Post,
Kudubhisanaahalli, Bangalore Urban,
Karnataka-560103

3. Guard File

Date:29.11.2019

F.No.9-65/RIFD/MOD/Policy-1/2018-19

All India Council for Technical Education
(A Statutory Body under Ministry of HRD, Govt. of India)
Nelson Mandela Marg, Vasant Kunj, New Delhi-110070 Website: www.aicte-india.org



MODROB - Sanction Letter

F.No.9-65/RIFD/MOD/Policy-1/2018-19

Date: 02.12.2019

To,
The Drawing and Disbursing Officer,
All India Council for Technical Education,
Nelson Mandela Marg, Vasant Kunj,
New Delhi- 110070.

Sub: Release of a sum of Rs.1200000/- (Rupees Twelve Lakh Only) being the Grant-in-Aid under the scheme Modernization and Removal of Obsolescence (MODROB) for the year 2018-19 payable during the current financial year 2019-20- reg.

Sir,

With reference to the proposal submitted by the institute, this is to convey that the sanction of the Council for payment of Rs.1500000/- (Rupees Fifteen Lakh Only) as Grant-in-Aid under the Modernization and Removal of Obsolescence (MODROB) scheme, as per details given below:

1.	Name and address of the Beneficiary Institution:	Director/ Principal/ Registrar, NEW HORIZON COLLEGE OF ENGINEERING (E&T), RING ROAD, NEAR MARATHALLI, BELLANDUR POST, KADUBHISANAHALLI Karnataka -560103.		
2.	Title of Project:	Modernization of Concrete Technology Lab & Removal of Obsolescent Equipment's		
3.	Name of Coordinator:	Dr. NIRANJAN P S		
4.	Duration of the project:	2 Years		
4.	Total Grant-in-aid Sanctioned:	Total: Rs.1500000/-	Non-Recurring (85%): Rs.1275000/-	Recurring (15%): Rs.225000/-
5.	Amount to be released during the year 2019-20:	1st Installment Rs.1200000/-	Non-Recurring (85%): Rs.1020000/-	Recurring (15%): Rs.180000/-
6.	Sanctioned grant-in-aid is debitible to:	Major Head 601.18(a) Gen. (Plan Head)		

1. The amount of the Grant shall be drawn by the Drawing and Disbursing Officer, All India Council for Technical Education on the Grant-in-Aid bill and shall be disbursed to and credited to the account of Director/Principal/ Registrar of the Institute through RTGS/PFMS.
2. This Grant-in-Aid is being released in conformity with the terms & conditions as well as norms of the scheme as already communicated, and also being communicated in this letter.

THE INSTRUCTIONS/GUIDELINES TO BE FOLLOWED BY UNIVERSITY/INSTITUTION

I. Release of funds:

- a. The Principal/ Director of the institute and the Coordinator of the project are hereby requested to verify the correctness of the undermentioned bank account/ RTGS details submitted by them along with the Proposal, in which the grant is being released:

Institute PAN No.	Bank Name	Bank Branch Name	Branch Address	Account Holder Name	Account Type	Account Number	IFSC
AAATN3061E	INDIAN BANK	NHCE Branch	Ring Road, Bellandur Post, New Marathalli, Bangalore - 560103	New Horizon College of Engineering	Current Account	484700078	IDIB000N112

Date:29.11.2019

- In case of any omission the same should be reported to AICTE immediately.
- The sanction is issued in exercise of the powers delegated to the council and other terms & conditions laid down in the guidelines of the scheme.
 - 100% grant of the sanctioned amount is being released to Government/Govt. Aided institutions. Utilization Certificate (UC) and other requisite documents are to be submitted within one month of the completion of the project.
 - To self-financed/Pvt. Institutions 80% of the sanctioned amount is being released as first installment followed by 20% as reimbursement after receipt of UC and other requisite documents as specified in terms & Conditions of MODROB Scheme.

II. Maintenance of accounts:

- The Institute shall strictly follow the provisions laid down in the scheme document and sanction order No. F.No.9-65/RIFD/MOD/Policy-1/2018-19 Dated 02.12.2019 issued by this office. All correspondences related to the project must contain this number along with year of sanction of the project; failing which correspondence will not be entertained
- Funds covered by this grant shall be kept separately and would not be mixed up with other funds, so as to know the amount of interest accrued on the grant AICTE.
- The University/College/Institute shall maintain proper accounts of the expenditure out of the grants, which shall be utilized only on approved items of expenditure (list enclosed).
- The Council or its nominee shall have the right to check /verify the account to satisfy that the fund has been utilized for the purpose for it was sanctioned.
- The date of release of the grant by AICTE shall be taken as the date of commencement of the project. The Principal / Director / Registrar shall intimate about the receipt of the grant to AICTE. Any expenditure incurred prior to the issuance of the approval letter will not be allowed to be adjusted in the grant and if the Institution / University do not take the project work within one month of the receipt of the grant, the approval shall ipso facto lapse.
- After receipt of the grant from AICTE, the Institute shall send a confirmation to AICTE within 2 months of receipt of grant that the sanctioned project has been started/is in progress.

III. Refund of grant by way of a demand draft in favour of Member Secretary, AICTE, New Delhi:

- If the college/institute does not have the Letter of Approval (LOA) or Extension of Approval issued by AICTE for the academic year 2019-20, the fund released should be immediately refunded to AICTE with interest accrued thereon.
- If project is not started within six months of the issuance of this Offer Letter, the released amount, along with interest accrued thereon, has to be necessarily returned to AICTE.
- In any case, if the institute is required to refund the grant or interest accrued thereon or balance amount, the amount will be refunded to AICTE.
- It may be ensured that the project is completed within the stipulated time. If the project is not completed in time, no further extension will be granted in any case and institute has to refund the entire amount to AICTE.
- As AICTE needs adequate time for depositing the Demand Draft in the bank, the same be immediately dispatched to avoid any lapse of the validity period.

IV. Submission of documents by college/institution after completion of Project/Subsequent years:

The following mandatory relevant documents are required to be submitted by the college/institution within one month of the completion of the project: -

- Feedback form in the prescribed proforma.
- The Annual Progress Report (APR) in the prescribed format along with the original Statement of actual Expenditure in the prescribed proforma duly signed by the Head of the institution and shall be submitted to AICTE not later than one month after completion.
- The Utilization Certificate (UC) supported by Audited Statement of Expenditure to the effect that the grant has been utilized for the purpose for which it has been sanctioned shall be furnished to the AICTE immediately after completion of the project. It should contain the head-wise break up

- of expenditure made from the grant-in-aid provided by the Council. Audited Statement of Expenditure indicating expenditure incurred in the total duration of the project in the prescribed format and GFR-19 shall be submitted to the Council.
- d) In case of self-financing/private institutions, Statement of actual Expenditure & Utilization Certificate are required to be audited & signed by a Chartered Accountant (with membership no., full address & stamp). Photocopies of formats are enclosed.
 - e) Program Evaluation Committee (PEC) is required to be constituted at Institutional level. The constitution of the PEC shall be as under:
 - i. Principal/Director/Registrar of the Institution(Chairperson)
 - ii. Coordinator of the project (Member Secretary),
 - iii. Two HODs and one subject expert(Members).
 - iv. The members of the said PEC shall not be below the rank of Associate Professor. The minutes of the meetings are to be submitted to the Council at end of the project along with other mandatory documents.
 - f) Project completion report project indicating the activities undertaking, number of students benefited, laboratory works photographs of students, together with their views is to be submitted.
 - g) Attested photocopies of supporting vouchers/bills of expenditure incurred for the completion of Project.
 - h) Photographs of equipment's purchased.
 - i) The balance amount of the grant will be reimbursed to the university/institution only on submission of the above documents. On receipt of these documents, the total amount of balance of financial assistance, admissible as per the norms, shall be worked out and grant-in-aid shall be released, as second installment, in favour of the beneficiary institution.

V. General instructions

- a) The amount of interest accrued on the grant should be treated as part of the grant to be utilized for that particular project. However, the interest amount accrued along with grant disbursed should not exceed the total grant sanctioned for the project. The Institute receiving the grant should reflect the same in the audited statement of accounts/ utilization certificate and may either refund the interest amount to AICTE or AICTE shall adjust the same in the next installment of grant before its release.
- b) Any unavoidable circumstantial change in the project with respect to name of Project Coordinator for the MODROB project would mandatorily require prior approval of the Council. All such requests should be addressed to AICTE, in advance, recording the specific reasons for proposed changes, failing which the offer for the grant already issued would be treated as automatically withdrawn and the financial assistance released in favour of the beneficiary institution shall be refunded immediately to the Council. Kindly mention the File No.9-65/RIFD/MOD/Policy-1/2018-19 in your future correspondence.
- c) The grantee shall maintain an audited record of assets acquired wholly or substantially out of the Grant-in-Aid and a register of assets shall be maintained by the Institute in the prescribed form i.e.GFR-19.
- d) The College / Institute receiving grant under MODROB is expected to put up a plaque at the main entrance of the Lab/Department, which has been modernized using the grant. All the equipment procured through the project should be super scribed with AICTE project file number.
- e) The assets acquired wholly or substantially out of grant shall not be disposed or encumbered or utilized for the purpose other than those for which the Grant was given without proper sanction of the AICTE and should at any time the institution cease to function, such assets shall revert to the AICTE.
- f) The grantee Institution shall observe all financial norms and guidelines as prescribed by the AICTE/ Government of India from time to time. GOI GFR rules (@<https://doe.gov.in/order-circular/general-financial-rules2017-0>) should be followed during utilization of grant.

Date:29.11.2019

F.No.9-65 /RIFD/MOD/Policy-I/2018-19

List of Equipment's approved :

Name of Equipments
Digital compression testing machine
Pundit ultrasonic pulse velocity and pulse echo tomography testing
Universal Testing Machine (Digital) UTM400D
a. Concrete Coring Machine & Stand b. 75 / 100 mm Core Bit c. Electrical drill & drill bit d. Hammer & Scissors e. Drop in anchor, tread & nut

Yours sincerely,

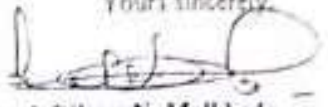
Prof. Dileep N. Malkhede
Advisor-1 (RIFD)

16 DEC 2019

Copy forwarded for information and necessary action to:

1. Name and Address of the Coordinator,
Dr. NIRANJAN P S,
NEW HORIZON COLLEGE OF ENGINEERING (E&T),
RING ROAD, NEAR MARATHALLI, BELLANDUR POST,
KADUBHISANAHALLI Karnataka -560103.
2. The Registrar / Director / Principal,
NEW HORIZON COLLEGE OF ENGINEERING (E&T),
RING ROAD, NEAR MARATHALLI, BELLANDUR POST,
KADUBHISANAHALLI Karnataka -560103
3. Guard File

Prof. Dileep N. Malkhede
Advisor-1 (RIFD)

All India Council for Technical Education

(A Statutory body under Ministry of HRD, Govt. of India)
Nelson Mandela Marg, Vasant Kunj, New Delhi-110070 Website: www.aicte-india.org



FDP - Sanction Letter

To
The Drawing and Disbursing Officer,
All India Council for Technical Education,
Nelson Mandela Marg,
Vasant Kunj,
New Delhi - 110070.

Sub: Release of a sum of Rs 250000/- for conduct of Faculty Development Programme (FDP)- reg.

Sir,

This is to convey the sanction of the Council for payment of Rs. 250000/- (Rupees Two Lakh Fifty Thousand Only) for conduct of FDP on RESEARCH PERSPECTIVES ON POWER CONVERTERS, CONTROLS AND HYBRID GRID INTEGRATION OF RENEWABLE ENERGY SOURCES to NEW HORIZON COLLEGE OF ENGINEERING (E&T), BANGALORE URBAN, Pin No- 560103, Karnataka, under the Scheme of Faculty Development Programme.

1. The amount of the grant shall be drawn by the Drawing and Disbursing Officer, All India Council for Technical Education on the grant-in-aid bill and shall be disbursed to and credited to the Registrar/ Director/Principal of the institute through RTGS.
2. This grant-in-aid is being released in conformity with the terms & conditions as well as norms of the scheme as already communicated, and also being communicated in this letter.
3. The sanctioned amount is debit to the Major Head 602.6(a) Gen. of the Scheme of Faculty Development Programme and is valid for payment during the financial year 2019-20.

The instructions/guidelines to be followed by University/Institution

I. Release of funds and maintenance of accounts

- a. The Principal of the institute and the Coordinator of the program are requested to verify the correctness of the under mentioned bank account/ RTGS details submitted by them along with the Proposal, in which the grant is being released.

Institute PAN No.	Bank Name	Bank Branch Name	Bank Branch Address	Account Holder Name	Account Type	Account Number	IFSC Code
AAATN3081E	INDIAN BANK	NEW HORIZON COLLEGE OF ENGINEERING	BENGALURU	NEW HORIZON COLLEGE OF ENGINEERING	Current Account	484700078	IDIB00DN112

In case of any omission the same should be reported to AICTE immediately

- b. The Institute shall strictly follow the provisions laid down in the scheme document and sanction order no. F. No. 34-55/132/RIFD/FDP/Policy-1/2017-18 dated 14.05.2019 issued by this office.
- c. Funds covered by this grant shall be kept separately and would not be mixed up with other funds so as to know the amount of interest accrued on the grant.
- d. The University/College/Institute shall maintain proper accounts of the expenditure out of the grants, which shall be utilized only on approved items of expenditure.
- e. The grant is intended to cover items of expenditure connected with the Faculty Development Programme such as Boarding & Lodging to the participants, TA to outstation participants, Honorarium to Course Coordinator, reading material to participants, Honorarium to resource persons, TA/DA to resource persons including two outstation resource persons & working expenses (reprographic services, postage, transport, daily wages, tea/coffee etc).

- f. The grant is subject to the adjustment on the basis of Utilization Certificate in the prescribed proforma to be submitted by the University/College/Institution. Further, the accounts of the institute will be open for test check by the Council & Controller & Auditor General of India or any other officer designated by them.

II. Disbursement of funds to institutions

- a. The full amount of the grant sanctioned is being released as advance to the University/Institute.
- b. The amount spent by the institute on the conduct of FDP shall be adjusted on the basis of utilization certificate and detailed expenditure statement submitted by the University/Institution on the prescribed format along with other mandatory documents viz feedback form, copy of proceedings and completion report etc.
- c. The above said amount of the grant shall be released on the basis of the Letter of Approval (LOA) issued by AICTE to the institute for the academic year 2019-20.

III. Conduct of test and issuance of certificate

A test shall be conducted by Program Evaluation Committee (PEC) at the end of the program and the certificates shall be issued to those participants who have attended the program and have qualified in the test.

IV. Submission of documents by university/institution

- a. The following mandatory relevant documents are required to be submitted by the university/institution within one month of the completion of the program:
 - (i) Original Statement of actual expenditure & Utilization Certificate in the prescribed proforma duly signed by the Head of the institution and countersigned by Registrar/Finance Officer/Govt. Auditor in case of self-financing/private institutions. Statement of actual Expenditure & Utilization Certificate are required to be audited & signed and sealed by a Chartered Accountant endorsing the membership number and complete postal address. Photocopies of formats are enclosed.
The university/institution is not required to submit bills/vouchers/invoices etc for the expenditure incurred out of recurring grants. However, such copies of bills/vouchers/invoices shall be digitized by respective institutions receiving grant and uploaded scanned copies of such bills/vouchers/invoices etc on the portal for availability and view at any point of time.
 - (ii) Feedback form in the prescribed proforma.
 - (iii) Copy of the proceedings and completion report.
 - (iv) List of candidates who have successfully completed the program on the basis of the test conducted by Program Evaluation Committee (PEC).
 - (v) Report submitted by Program Evaluation Committee (PEC).
- b. The amount of the grant shall be adjusted on submission of utilization certificate & detailed expenditure statement by University/Institution. On receipt of these documents, the total amount of financial assistance, admissible as per the norms, shall be worked out and grant-in-aid shall be adjusted.
- c. The university/institution is expected to submit the above said mandatory documents viz Utilization certificate, Expenditure Statement and feedback form etc within one month of conduct of FDP. However, delay of further 2 months may be condoned by AICTE in special circumstances as explained by the institute. Delay in submission of documents after three months of the conduct of FDP shall invite a penalty of 10% of the total sanctioned amount of the FDP to be deducted from the balance amount of 2nd installment. The entire amount of grant already released, along with interest accrued thereon shall be refunded to AICTE if mandatory documents are not submitted by the institute beyond one year.

V. General Instructions

- a. Preferably 10% of the participants may be industry professionals deputed by industry. Further, not more than 20% participants shall be from the host institution/group of institutions.
- b. Interest, accrued on the grant released shall be refunded back to AICTE.
- c. If programme is not conducted in the period of nine months of the issuance of this Offer Letter, the released amount, along with interest accrued thereon, has to be returned back to AICTE.
- d. The expenditure under the Heads 'Honorarium to Course Coordinator' and 'Honorarium to Resource Persons' shall not exceed 1% & 20% respectively of the total sanctioned grant for the Programme. However, overall expenditure shall not exceed the funds sanctioned for the Programme.
- e. Any extra money required to complete the programme must be borne by the institute from their own resources. But the quality of the activities should not be compromised.

Dated: 10 May 2019

F. No. 34-55/____/RIFD/FDP/Policy-10017-18

- f. The FDP will be organized for 2 weeks with minimum 40 participants. The approved FDP shall be conducted within nine months from the date of release of funds.
- g. Any unavoidable circumstantial change in the Program with respect to name of Project Coordinator, Venue and date for organizing FDP would mandatorily require prior approval of the Council. All such requests should be addressed to AJCTE, in advance, recording the specific reasons for proposed changes, failing which the offer for the grant already issued would be treated as automatically withdrawn and the financial assistance released in favour of the beneficiary institution shall be refunded immediately to the Council. Kindly mention the File No. 34-55/____/RIFD/FDP/Policy-1/2017-18 in your future correspondence.
- h. Program Evaluation Committee (PEC) is required to be constituted at institutional level. The constitution of the PEC shall be as under:
- Principal/Director/Registrar of the institution (Chairperson).
 - Coordinator of the program (Member Secretary).
 - Two HODs and one subject expert (members).
- The members of the said PEC shall not be below the rank of Associate Professor. A test shall be conducted by Program Evaluation Committee (PEC) at the end of the program and the certificates shall be issued to those participants who have attended the program and have qualified in the test. The minutes of the meetings, along with PEC report, are to be submitted to the Council at end of the program along with other mandatory documents.
- i. GOI GFR rules ([@https://doe.gov.in/order-circular/general-financial-rules2017-0](https://doe.gov.in/order-circular/general-financial-rules2017-0)) should be followed during utilization of grant.
- j. This Sanction Order may be treated as Offer Letter for all purposes.

Yours sincerely,

(Dileep N. Malkhede)
Advisor-I, RIFD
28/5/19

Copy forwarded for information and necessary action to -

1. Coordinator of the Program

Dr. SUJITHA S
NEW HORIZON COLLEGE OF ENGINEERING (E&T)
RING ROAD, NEAR MARATHALLI, BELLANDUR POST,
KADUBHISANAHALLI BANGALORE URBAN
BANGALORE - 560103

2. The Registrar / Director / Principal

NEW HORIZON COLLEGE OF ENGINEERING (E&T)
RING ROAD, NEAR MARATHALLI, BELLANDUR POST,
KADUBHISANAHALLI BANGALORE URBAN
BANGALORE - 560103

3. Guard File

All India Council for Technical Education

(A Statutory body under Ministry of HRD, Govt. of India)

Nelson Mandela Marg, Vasant Kunj, New Delhi-110070 Website: www.aicte-india.org



STTP- Sanction Letter

Ref. No. 34-65/293/RIFD/STTP/Policy-1/2018-19

Date _____

To

The Drawing and Disbursing Officer,
All India Council for Technical Education,
Nelson Mandela Marg,
Vasant Kunj, New Delhi – 110070

Sub: Release of grant for conduct of Short Term Training Programme (STTP) under AQIS 2018-19 during the financial year 2019-20– reg.

Sir,

This is to convey the sanction of the Council for payment of **Rs. 250000 /- (Rupees Two Lakh Fifty Thousand Only)** for conduct of Short Term Training Program as per details given below:-

1.	Name and address of the beneficiary University / Institution	NEW HORIZON COLLEGE OF ENGINEERING (E&T) , RING ROAD, NEAR MARATHALLI, BELLANDUR POST, KADUBHISANAHALLI BANGALORE URBAN-560103 Karnataka
2.	Permanent ID of Institute	1-11989651
3.	Institute type	Unaided - Private
4.	Name of Coordinator	Dr. ANANDHI JAYADHARMARAJAN
5.	Amount sanctioned	Rs. 250000/-
6.	Amount to be released	Rs.250000/- Full & final payment
7.	Head of account	601.15(a) Gen. Short Term Training Programme (Plan)
8.	The authorized officer in whose favour Cheque/ Demand Draft/ RTGS is to be made	REGISTRAR / DIRECTOR / PRINCIPAL
9.	Title of the programme	Short Term Training Programme on Internet of Things (IoT) Applications

1. The amount of the grant shall be drawn by the Drawing and Disbursing Officer, All India Council for Technical Education on the grant-in-aid bill and shall be disbursed to and credited to the Registrar/ Director/Principal of the institute through RTGS.

2. This grant-in-aid is being released in conformity with the terms & conditions as well as norms of the scheme as already communicated, and also being communicated in this letter.
3. The Principal of the Institute and the Coordinator of the Program are requested to verify the correctness of the under-mentioned Bank Account / RTGS Details submitted by them alongwith the proposals, in which the grant is being released:-

Institute PAN No.	Bank Name	Bank Branch Name	Bank Branch Address	Account Holder Name	Account Type	Account Number	IFSC Code
AAATN3061E	INDIAN BANK	NHCE Branch	Ring Road, Kadubeesanahalli, Near Marathalli, Bangalore - 560016	New Horizon College of Engineering	Current Account	484700078	IDIB000N112

Instructions/Guidelines to be followed by the University/Institution

I. Disbursement of funds to University/Institutions

- a. The full amount of the grant sanctioned is being released as advance to the University/Institute.
- b. The amount spent by the institute on the conduct of STTP shall be adjusted on the basis of utilization certificate and detailed expenditure statement submitted by the University/Institution on the prescribed format along with other mandatory documents viz feedback form, copy of proceedings and completion report etc.
- c. The above said amount of grant shall be refunded back to AICTE if the Letter of Approval (LOA) / Extension of Approval (EOA) is not issued by AICTE to the institute for the academic year 2019-20.

II Maintenance of Accounts

- a. The Institute shall strictly follow the provisions laid down in the scheme document as available on the portal.
- b. Funds covered by this grant shall be kept separately and would not be mixed up with other funds so as to know the amount of interest accrued on the grant.
- c. The University/College/Institute shall maintain proper accounts of the expenditure out of the grants, which shall be utilized only on approved items of expenditure.
- d. The grant is intended to cover items of expenditure connected with the Short Term Training Programme such as Boarding & Lodging to the participants, TA to outstation participants, Honorarium to Course Coordinator, reading material to participants, Honorarium to resource persons, TA/DA to resource persons including two outstations resource persons & working expenses (reprographic services, postage, transport, daily wages, tea/coffee etc).

III. Conduct of test and issuance of certificate

A test shall be conducted by Program Evaluation Committee (PEC) at the end of the program and the certificates shall be issued to those participants who have attended the program and have qualified in the test.

IV. Submission of Documents by the University/Institutions to AICTE

- a. The following mandatory relevant documents are required to be submitted by the University/Institution within one month of the completion of the program:-
 - (i) Original Statement of actual expenditure & Utilization Certificate in the prescribed proforma duly signed by the Head of the institution and countersigned by Registrar/Finance Officer/Govt. Auditor. In case of self-financing/private institutions, Statement of actual Expenditure & Utilization Certificate are required to be audited & signed and sealed by a Chartered Accountant endorsing the membership number and complete postal address. Format for the same is available on AICTE web portal.

The University/Institution is not required to submit bills/vouchers/invoices etc for the expenditure incurred out of recurring grants. However, such copies of bills/vouchers/invoices shall be digitized by respective institutions receiving grant and uploaded scanned copies of such bills/vouchers/invoices etc on the portal for availability and view at any point of time.
 - (ii) Feedback form in the prescribed proforma.
 - (iii) Copy of the proceedings and completion report.
 - (iv) List of candidates who have successfully completed the program on the basis of the test conducted by Program Evaluation Committee (PEC).
 - (v) Report submitted by Program Evaluation Committee (PEC).
- b. The amount of the grant shall be adjusted on submission of utilization certificate & detailed expenditure statement by University/Institution. On receipt of these documents, the total amount of financial assistance, admissible as per the norms, shall be worked out and grant-in-aid adjusted.

V. General instructions

- a. **Preferably 10% of the participants may be industry professionals deputed by industry. Further, not more than 2 participants shall be from the host institution/group of institutions.**
- b. **Money to be reimbursed on the grant (for any reasons to include unspent amount, interest , penalty if imposed) shall be refunded back to AICTE in the form of Demand Draft payable to Member Secretary, AICTE, New Delhi.**
- c. **As AICTE needs adequate time for depositing the Demand Draft in the bank, the same be immediately dispatched to avoid any lapse of the validity period.**
- d. **The STTP is a residential program of a duration of six days with minimum 40 participants.** The approved STTP shall be conducted within three months from the date of release of funds.
- e. **If programme is not conducted in the period of three months of the issuance of this Sanction Order, the released amount, alongwith interest accrued thereon, has to be necessarily returned back to AICTE within a month.**
- f. The expenditure under the Heads '**Honorarium to Course Coordinator**' and '**Honorarium to Resource Persons**' shall not exceed **1% & 20% respectively** of

the total sanctioned grant for the Programme. However, overall expenditure shall not exceed the funds sanctioned for the Programme.

- g. Any extra money required to complete the programme must be borne by the institute from their own resources. But the quality of the activities should not be compromised.
- h. Any unavoidable circumstantial change in the program with respect to name of Project Coordinator, Venue and date for organizing STTP would mandatorily require prior approval of the Council. All such requests should be addressed to AICTE, in advance, recording the specific reasons for proposed changes, failing which the offer for the grant already issued would be treated as automatically withdrawn and the financial assistance released in favour of the beneficiary institution shall be refunded immediately to the Council. Kindly mention the File No. 34-65/293/RIFD/STTP/Policy-1/2018-19 in your future correspondence
- i. **Program Evaluation Committee (PEC)** is required to be constituted at institutional level. The constitution of the PEC shall be as under:
 - (i) Principal/Director/Registrar of the institution (Chairperson).
 - (ii) Coordinator of the program (Member Secretary).
 - (iii) Two HoDs and one subject expert (members).

The members of the said PEC shall not be below the rank of Associate Professor. A test shall be conducted by Program Evaluation Committee (PEC) at the end of the program and the certificates shall be issued to those participants who have attended the program and have qualified in the test. The minutes of the meetings, along with PEC report, are to be submitted to the Council at end of the program along with other mandatory documents.

- j. **GoI GFR rules** (@<https://doe.gov.in/order-circular/general-financial-rules2017-0>) should be followed during utilization of grant
- k. This Sanction Order may be treated as Offer Letter for all purposes.

NOTE:- Any deviation from the above will invoke serious action against the Institute.

Yours sincerely,

(Dileep N Malkhede)
Advisor-I (RIFD)

Copy forwarded for information and necessary action to :-

12 DEC 2019

1. **Name and Address of the Coordinator**
Dr. ANANDH JAYADHARMARAN
NEW HORIZON COLLEGE OF ENGINEERING (E&T)
RING ROAD, NEAR MARATHALLI, BELLANDUR POST, KADUBHISANAHALLI
BANGALORE 560103 Karnataka
2. **The Registrar / Director / Principal**
NEW HORIZON COLLEGE OF ENGINEERING (E&T)
RING ROAD, NEAR MARATHALLI, BELLANDUR POST, KADUBHISANAHALLI
BANGALORE 560103 Karnataka
3. **Guard File**

All India Council for Technical Education
(A Statutory body under Ministry of HRD, Govt. of India)
Nelson Mandela Marg, Vasant Kunj, New Delhi-110070 Website: www.aicte-india.org



GOC - Sanction Letter for E-Conference

To

The Director/ Principal/ Registrar
New Horizon College of Engineering (M & T),
Ring Road, Near Marathalli, Kadubhisanaahalli,
Bellandur-Post, Bangalore Urban, Bangalore,
Karnataka-560103

Subject: To organize Conference in online mode i.e. E-Conference under the scheme Grant for Organizing Conference (GOC)-reg.

Sir/ Madam,

With reference to the proposal submitted by your institute, this is to convey that an amount of Rs. **1,53,333/- (Rupees One lakh fifty three thousand three hundred thirty three only)** was sanctioned and released to your institute in the month of March-2020 for organizing Conference under the scheme Grant for Organizing Conference (GOC), as per details given below:

1.	Name and address of the Beneficiary Institution.	Director/ Principal/ Registrar New Horizon College of Engineering (M & T), Ring Road, Near Marathalli, Kadubhisanaahalli, Bellandur-Post, Bangalore Urban, Bangalore, Karnataka-560103
2.	Permanent ID of Institute	1-12514811
3.	Title of Conference.	Role of Management Practices in Business Sustainability in an era of Technological Disruptions
4.	Name of Coordinator	Dr. Sainath A R

The grant was released to the institute's amount as per details given in table below

Institute PAN No.	Bank Name	Bank Branch Name	Bank Branch Address	Account Holder Name	Account Type	Account Number	IFSC Code
AAAT N326 1E	INDIAN BANK	NICE Branch	Ring road, Kadubhisanaahalli, Bangalore	New Horizon College of Engineering	Current Account	484700078	IDIB000N112

The grant was released to organize the conference in physical mode, but due to outbreak of COVID 19, the Council has decided to give option to the institutions to organize the conference in online mode only i.e. E-Conference with additional terms and conditions

Note:

1. If your institute has organized the conference in the stipulated time, then you are intimated to submit the requisite documents along with balance amount, if any.
2. If your institute has not organized the conference after receipt of grant, then you are allowed to organize the conference in online mode i.e. E-Conference within 6 months of receipt of this letter.
3. If your institute does not want to organize the **E-conference**, then you are required to refund the complete grant along with the interest accrued thereon.
4. The grant from AICTE will be **Rs. 50,000 or 1/3rd of the total expenditure incurred** for organizing the **E-Conference**, whichever is lesser. Rest amount is required to be refunded to AICTE.

The instructions/guidelines to be followed by College/Institution

I. Limit of Funding

- a. The grant from AICTE will be **Rs. 50,000 or 1/3rd of the total expenditure incurred for organizing the E-Conference**, whichever is lesser.
- b. The balance amount should be immediately refunded to AICTE with interest accrued thereon.

There may be the following expenditure heads under E-Conference-

- a. Certificate/Brochure and other documents designing.
- b. Conference website designing & updating.
- c. Honorarium to Experts/ Resource Persons.
- d. Publication of proceedings.
- e. Miscellaneous.

II. Submission of documents by college/institution to AICTE on receipt of this letter/grant

- a. The Acceptance letter with dates for Organizing E-Conference should reach this office within 15 days from the date of receipt of this Sanction Letter duly signed and sealed by Coordinator and Head of the institution along with permission/clearance of Govt. of India for organizing E-Conference.

III. Maintenance of accounts

- a. The Institute shall strictly follow the provisions laid down in this letter No. F. No. 67-45/IDC/GOC/Policy-5/2019-20 dated: 24-06-2020 issued by this office. All correspondence related to the conference must contain this number along with year of sanction of the conference failing which correspondence will not be entertained.
- b. Funds covered by this grant shall be kept separately and would not be mixed up with other funds, so as to know the amount of interest accrued on the grant.
- c. The University/College/Institute shall maintain proper accounts of the expenditure out of the grant.
- d. The Council or its nominee shall have the right to check/verify the account to satisfy that the fund has been utilized for the purpose for it was sanctioned.

IV. Refund of grant to AICTE (by way of a demand draft in favour of Member Secretary, AICTE, New Delhi)

- a. In case the event is cancelled or institute does not want to organize the E-Conference, the fund released should be immediately refunded to AICTE with interest accrued thereon.
- b. The grant shall be refunded to AICTE if the letter of Approval (LOA) or Extension of Approval is not issued by AICTE to the institute for the academic year 2019-20.
- c. The proposed/approved E-Conference shall be conducted within 6 months from the date of receipt of this letter. If E-conference is not conducted within stipulated time period, the released amount, along with interest accrued thereon, has to be necessarily returned to AICTE within one month, failing which penalty @ 18% will be levied.
- d. Interest accrued on the grant released, shall be refunded to AICTE.
- e. No payment is permissible against the conference **already conducted** before the receipt of grant. Institutions are liable to refund the grant if received after the conduct of conference and have no plan of conducting the E-conference ahead.
- f. As AICTE needs adequate time for depositing the Demand Draft in the bank, the same be immediately dispatched to avoid any lapse of the validity period.

V. Submission of documents by college/institution to AICTE after conduct of conference

The following documents must be submitted to AICTE within a period of one month, from the date of conduct of Conference:

- a. **Feedback form** in the prescribed proforma.
- b. **Original Statement of actual Expenditure & Utilization Certificate** in the prescribed proforma duly signed by **the Head of the institution** and countersigned by Registrar/Finance Officer/Govt. Auditor. In case of self-financing/private institutions, **Statement of actual Expenditure & Utilization Certificate** are required to be audited & signed by a Chartered Accountant (with membership no., full address & stamp) Photocopies of formats are enclosed
- c. Copy of the proceedings/Project completion report.
- d. Attested photocopies of supporting vouchers/bills of expenditure incurred for Organizing Conference.
- e. Soft copy of photographs of conference.
- f. One video of 1 minute duration mentioning: (i). Introduction of the Coordinator mentioning the name and state of institute. (ii). Conference details and achievements attained through Conference (iii). How the Conference was beneficial to students, faculty and institute? (iv). Thanking message for AICTE support.

VI. General Instructions

- a. Any Change in the programme for holding Conference, change of Coordinator name, Venue and Date should be effected with prior approval of the Council, failing which the sanction for the grant already issued would be treated as automatically withdrawn.
- b. The assets acquired wholly or substantially of the All India Council for Technical Education's grants shall not be disposed or encumbered or utilized for the purposes other than those for which it was given without proper sanction of the Council and should, at any time the Institution ceased to function, such assets shall revert to the All India Council for Technical Education.
- c. The beneficiary institute will make best efforts to promote the scheme by mentioning the sponsorship/support from AICTE, carrying the Logo of AICTE in conference and other means.
- d. The grantee Institution shall observe all financial norms and guidelines as prescribed by the AICTE/ Government of India from time to time. GOI GFR rules (@<https://doe.gov.in/order-circular/general-financial-rules2017-0>) should be followed during utilization of grant.

Yours sincerely,

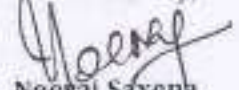
Neeraj Saxena
Advisor (IDC)

Copy forwarded for information and necessary action to:

1. **Name and Address of the Coordinator**
Dr. Sainath A R.
New Horizon College of Engineering (M & T),
Ring Road, Near Marathalli, Koduhhisahalli,
Bellandur Post, Bangalore Urban, Bangalore,
Karnataka-560103

2. Guard File



Ref: UNITYsat/TSC/SlimSat/Indo-Serbia/003

26 July 2019

To

The Principal (Attention to Prof & HoD, Dept of ECE/EEE)
New Horizon College of Engineering (NHCE)
Outer Ring Road, Kadubesnahalli, Bangalore, Karnataka

Sanction of Development of SDR for UNITYsat and LoRa Interface, OBC and Subsystems with Firmware; Testing and Qualifications for Launch to LEO (Timeline: 9 Months). Indo-Serbia Joint Development Project: 2019-20)-Rs. 25,00,000/-

Dear Professor,

SUB: Sanction of Matching Grant-Joint Development-Development of SDR for UNITYsat and LoRa Interface, OBC and Subsystems with Firmware; Testing and Qualifications for Launch to LEO -9 Months (2019-20)-Rs.25,00,000/-(In Cash/Kind)Reg.

REF: Your Project Proposal in Response to Announcement of Opportunity-Our Interactions/On-line Meetings/MoU Signed with Your Institution on 05 April 2016

Under the powers vested with Programme Office for the UNITYsat Programme as per the TSC-ITCA-CSPD Consortium which has signed MoU on 05 April 2016 and subsequent Announcement of Opportunity issued, I am directed to convey the sanction of the following projects for the year 2019-20:

2019-20 (Project Split-up Among Departments)	Funding in Rs.
Dept. ECE: 6 Months: UNITYsat, SDR, LoRa Interface, Onboard Systems and Subsystems: Firmware Coding, Antenna Deployment, Integration Services, Testing and Qualifications for Launch etc	10,00,000/-
Dept. EEE: 9 Months: Electrical Power Supply (EPS) System for UNITYsat, Space Qualification Testing and Validation for Launch Vehicle (PSLV) for LEO etc-Phase 2	15,00,000/-

1. Funds for second installment will be released on satisfactory progress and submission of six month progress report by PI to the Programme Office and based on recommendation with due approval of competent authority.
2. Statement of accounts and utilization certificate duly certified by the executive financial authority of the Institution is also required to be submitted along with the annual report. Excess expenditure, beyond the sanctioned amount, shall be responsibility of grantee institution.
3. The duration of the project is TEN MONTHS with review after six months! The date of receipt of the grant would be reckoned as the commencement date of the project which has to be intimated to the Programme Office without any ambiguity.
4. A separate account for the grant would be maintained by New Horizon College of Engineering and any interest earned thereon, if any, would accrue to UNITYsat Programme.
5. Unspent balance, on completion of the project should be sent by the grantee institution through a RTGS/Cheque/Draft in the name of TSC Technologies P Ltd, Bangalore for doing the needful.
6. A list of inventory of equipment purchased out of the Programme grant shall be intimated year-wise, along with its cost and source of procurement to the Programme Office.
7. On completion of the project, the grantee institution would forward the consolidated list with request, if any, for the retention of any equipment for another project or in-house R&D, with due recommendations of their executive authority and the concerned panel.
8. In case of any joint publications of Technical Research Papers related to this project as a part/outcome of the research works shall have the mentioning/acknowledgement of consortium which has granted the matching grant for the project appropriately.

1. A Closure Report alongwith copies of technical report may be submitted within sixty days of completion of project alongwith Statement-2 (Statement of Expenditure) and Statement -3 (Utilization Certificate) as per the Annexure III of Grants-in-aids rules duly audited from the Audit Authority of Institution signed in ink in duplicate.
2. TSC Technologies P Ltd, Bangalore will make disbursement of money/equivalent in kind as sanctioned.

With Warm Regards,

Yours Sincerely,

Nikhil

(NIKHIL RIYAZ)

Director

TSC Technologies Private Limited

M: +91 97418 96297

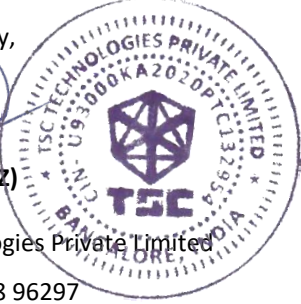

Copy to

- a) Programme Director, UNITYsat Programme Office, Bangalore
- b) President, Indian Technology Congress Association
- c) Head, Committee for Space Programme Development, Serbia
- d) Convener, 75 Students' Satellites Consortium: Mission 2022
- e) Professor and HoD, ECE/EEE, NHCE, Bangalore





Karnataka Science and Technology Promotion Society

Dept. of Information Technology, Bio Technology and Science & Technology, GoK
"Vijnana Bhavan", 3rd Floor, #24/2, 21st Main Road, Banashankari 2nd Stage, Bangalore-70
Ph/fax : 080-26711166, E-mail : ksteps.dst@gmail.com

Dr. H. Honne Gowda
Special Director (Technical),
Dept. of IT, BT and S&T/ Managing director, KSTePS

No. KSTePS/VGST-RGS/F/GRD No.730/2017-18

Date: 27.08.2018

Dear Sir/Madam,

Sub: Intimation of selection of RGS/F Project under the VGST scheme -reg.

Greetings from KSTePS, Dept. of Information Technology, Biotechnology and Science and Technology!!

We are pleased to inform you that the RGS/F Engineering program titled "**Investigations on use of Current Source Inverters (CSI) for Grid connected solar PV for Residential/Apartment applications**" submitted under the VGST scheme for the Financial Year 2017-18 has been approved by the Government based on the recommendations of Vision Group on Science and Technology under the Chairmanship of Prof. CNR Rao, Honorary President, JNCASR. You may kindly initiate necessary action for organization of the program at the earliest.

Please provide the cheque in favour address of your Institution, for releasing the sanctioned grants.

I want to personally thank you for being selected as one of the VGST program members and we wish you a great success in organization of the program.

Thanking You,

Yours sincerely,

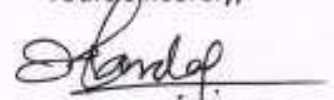
Managing Director

To,
The Principal
New Horizon College of Engineering
Outer Ring Road, Near Marathahalli
Bellandur Main Road, Bengaluru-560 103

CC: 1. Dr. Nisha K. C. R., Dept. of ECE, New Horizon College of Engineering, Outer Ring Road, Near Marathahalli, Bellandur Main Road, Bengaluru-560 103 - **RGS/F Grantee.**

2. Consultant, Vision Group on Science and Technology, KSTePS, Dept. of IT, BT and S&T
Karnataka Government Secretariat, Room No. 702, 7th Floor, 4th Gate, M. S. Building
Dr. Ambedkar Veedhi, Bangalore- 560 001

State Bank of India
State Bank Of India

(DOMS) - RAMANASHREEARCDAHANAHARISTG
PO NO 7079 21ST MAIN OFF B D A COMPLEX
DANASHANKAR B STD, BLDING 593070
Tel. 00-26718753 B/D Code: SBIN0004463

18092018
D O M M Y Y Y Y

Principal, NHCE
रुपये RUPEES Five Lakhs Only

या धारक को OR BEARER

अदा करे ₹ 5,00,000/-

64110830474

VALID UPTO ₹ 10 LACS AT NON-HOME BRANCH

SB ACCOUNT

PREFIX:
1515500083

[Signature]
MANAGING DIRECTOR, KARNATAKA SCIENCE AND
TECHNOLOGY PROMOTION SOCIETY

MULTI-CITY CHEQUE Payable at Par at All Branches of SBI

Please sign above

006009 560002380: 010137* 31

Dr. Nisha KCR
ECE



ಕರ್ನಾಟಕ ವಿಜ್ಞಾನ ಮತ್ತು ತಂತ್ರಜ್ಞಾನ ಪ್ರೋತ್ಸಾಹಕ ಸೂಚನೆ

ಮಾಹಿತಿ ತಂತ್ರಜ್ಞಾನ, ಜೈವಿಕ ತಂತ್ರಜ್ಞಾನ ಹಾಗೂ ವಿಜ್ಞಾನ ಮತ್ತು ತಂತ್ರಜ್ಞಾನ ಇಲಾಖೆ, ಕರ್ನಾಟಕ ಸರ್ಕಾರ
'ವಿಜ್ಞಾನ ಭವನ' ನಂ: 24/2, 3ನೇ ಮಹಡಿ, 2ನೇ ಮುಖ್ಯ ರಸ್ತೆ, ಬನಶಂಕರಿ 2ನೇ ಹಂತ, ಬೆಂಗಳೂರು-560 070
ದೂರವಾಣಿ/ಫ್ಯಾಕ್ಸ್: 080-26711166 / 26711160 ಇ-ಮೇಲ್: ksteps.dst@gmail.com

ಡಾ. ಹೆಚ್. ಹೊನ್ನೇಗೌಡ
ವ್ಯವಸ್ಥಾಪಕ ನಿರ್ದೇಶಕರು, ಕೆಸ್ಪೆಪ್ಸ್

ನಂ. KSTePS/VGST/FDP-Eng. /2017-18/FDP-02/71/2018-2019

ದಿನಾಂಕ: 17.09.2018

ಮಾನ್ಯರೇ,

ವಿಷಯ: 2017-18ನೇ ವಿಜ್ಞಾನ ಮತ್ತು ತಂತ್ರಜ್ಞಾನ ದಾರ್ಶನಿಕ ಸಮೂಹದ FDP-Eng. ಯೋಜನೆಯಡಿಯಲ್ಲಿ
ಅನುದಾನ ಬಿಡುಗಡೆ ಮಾಡುವುದರ ಬಗ್ಗೆ.

ಉಲ್ಲೇಖ: 1) ಸರ್ಕಾರಿ ಆದೇಶ ಸಂಖ್ಯೆ: ವಿಯಇ 154 ವಿತ್ರಮ 2018(ಭಾಗ-2), ದಿ: 18.08.2018

2) ಕಛೇರಿ ಪತ್ರ ಸಂಖ್ಯೆ: No. KSTePS/VGST-FDP-Eng./2017-18/156, Date: 27.08.2018

ಮೇಲ್ಕಂಡ ವಿಷಯ ಮತ್ತು ಉಲ್ಲೇಖಗಳಿಗೆ ಸಂಬಂಧಿಸಿದಂತೆ, 2017-18ನೇ ಸಾಲಿನಲ್ಲಿ ತಮ್ಮ
ಸಂಸ್ಥೆಯಿಂದ ಸಲ್ಲಿಸಿದ ಪ್ರಸ್ತಾವನೆಯಾದ "Data acquisition and control systems" ನ್ನು ವಿತಂದಾಸದ
ಪ್ರಮುಖ ಕಾರ್ಯಕ್ರಮವಾದ Faculty Development Program-Engg ನ ಯೋಜನೆಯಡಿಯಲ್ಲಿ ವಿಜ್ಞಾನ
ಮತ್ತು ತಂತ್ರಜ್ಞಾನ ದಾರ್ಶನಿಕ ಸಮೂಹವು ಆಯ್ಕೆ ಮಾಡಿದ್ದು, ಅದರಂತೆ ಆದೇಶ ನೀಡಿರುವುದು ಸರಿಯಷ್ಟೆ.

ಈ ಸಂಬಂಧ, ವಿತಂದಾಸದ FDP-Engg ಯೋಜನೆಯಡಿ ಆಯ್ಕೆಯಾದ ತಮ್ಮ ಸಂಸ್ಥೆಗೆ ರೂ. 2.00
ಲಕ್ಷಗಳ ಅನುದಾನವನ್ನು ಬಿಡುಗಡೆ ಮಾಡಲು ದಿನಾಂಕ: 17.09.2018 ರಂದು Principal, NHCE ಹೆಸರಿನಲ್ಲಿ
ಚೆಕ್ (ಸಂ. 005978) ಬರೆದು, ಸದರಿ ಚೆಕ್‌ನ್ನು ಈ ಪತ್ರದೊಂದಿಗೆ ಲಗತ್ತಿಸಿ ಕಳುಹಿಸಿಕೊಡಲಾಗಿದೆ.
ಮುಂದುವರಿದು, ಚೆಕ್ ಸ್ವೀಕರಿಸಿದ ನಂತರ ಸ್ವೀಕೃತಿ ರಶೀದಿ (Acknowledgement) ಯನ್ನು ಕೆಸ್ಪೆಪ್ಸ್‌ಗೆ
ಕಳುಹಿಸುವುದು ಹಾಗೂ ಸದರಿ ಅನುದಾನವನ್ನು ಯಾವುದಾದರೂ ರಾಷ್ಟ್ರೀಕೃತ ಬ್ಯಾಂಕ್‌ಗಳಲ್ಲಿ ಉಳಿತಾಯ
ಖಾತೆಯಲ್ಲಿಟ್ಟು (Saving Bank Account) ಅಗತ್ಯಕನುಗಣವಾಗಿ ಅನುದಾನವನ್ನು ಬಳಸುವಂತೆ
ಕೋರಲಾಗಿದೆ.

ಸದರಿ ಅನುದಾನವನ್ನು ಉದ್ದೇಶಿತ ಯೋಜನೆಗೆ ಮಾತ್ರ ಬಳಸಿಕೊಳ್ಳುವುದು ಹಾಗೂ ಎಲ್ಲಾ ವೆಚ್ಚಗಳನ್ನು
ಕರ್ನಾಟಕ ಸಾರ್ವಜನಿಕ ಸಂಗ್ರಹಣೆಯಲ್ಲಿ ಪಾರದರ್ಶಕತೆ ಅಧಿನಿಯಮ, 1999 (Karnataka
Transparency in Public Procurements Act, 1999 - <http://finance.kar.nic.in/index.htm>)
ಅನುಸಾರ ಹಾಗೂ ದಾರ್ಶನಿಕ ಸಮೂಹ ಅನುಮೋದಿಸಿರುವ ವಿವಿಧ ಶೀರ್ಷಿಕೆಗಳಿಗೆ ಅನುಗುಣವಾಗಿ
ಯೋಜನೆಯನ್ನು ಅನುಷ್ಠಾನಗೊಳಿಸುವುದು.

ಮುಂದುವರಿದು, ಚಿಕ್ಕದೆಯಾದ ಅನುದಾನವನ್ನು ಬಳಸಿಕೊಂಡ ನಂತರ ಎಲ್ಲಾ ವೆಚ್ಚಗಳನ್ನು ನೋಂದಾಯಿತ ಲೆಕ್ಕ ಪರಿಶೋಧಕರಿಂದ ಆಡಿಟ್ ಮಾಡಿಸಿ, ಈ ಪತ್ರದೊಂದಿಗೆ ಲಗತ್ತಿಸಿರುವ ನಮೂನೆಯಲ್ಲಿ (Format) ದೃಢೀಕರಿಸಿದ ಖರ್ಚುಪತ್ರಗಳನ್ನೊಳಗೊಂಡ ಉಪಯೋಗತಾ ಪ್ರಮಾಣಪತ್ರವನ್ನು ದ್ವಿಪ್ರತಿಯಲ್ಲಿ ಕೆಸ್ಪೆಪ್ಪ್ ಸಂಸ್ಥೆಗೆ ಕಳುಹಿಸಿಕೊಡುವುದು. ಸದರಿ ಯೋಜನೆಗೆ ಸಂಬಂಧಪಟ್ಟ ಎಲ್ಲಾ ಲೆಕ್ಕ ಪತ್ರಗಳನ್ನು ಸಂರಕ್ಷಿಸಿಡುವುದು ಹಾಗೂ ಮಹಾಲೇಖಪಾಲಕರು ಮತ್ತು ಸರ್ಕಾರವು ತಪಾಸಣೆಗಾಗಿ ಕೋರಿದಲ್ಲಿ ತಪ್ಪದೇ ಒದಗಿಸುವುದು. ಈ ಯೋಜನೆಗೆ ಸಂಬಂಧಿಸಿದಂತೆ ಪ್ರತ್ಯೇಕ ದಾಖಲೆ ಪುಸ್ತಕವನ್ನು ಸಹ ನಿರ್ವಹಿಸಬೇಕೆಂದು ಕೋರುತ್ತೇನೆ.

ಹೆಚ್ಚಿನ ಮಾಹಿತಿಗಾಗಿ ಡಾ|| ಎಸ್. ಜಿ. ಶ್ರೀಕಂಠೇಶ್ವರ ಸ್ವಾಮಿ, ಸಮಾಲೋಚಕರು, ವಿಜ್ಞಾನ ಮತ್ತು ತಂತ್ರಜ್ಞಾನ ದಾರ್ಶನಿಕ ಸಮೂಹ ಇವರನ್ನು ಸಂಪರ್ಕಿಸಬಹುದು. ದೂರವಾಣಿ ಸಂಖ್ಯೆ 080- 2203 2013 ಇ-ಮೇಲ್: visiongroup.st@gmail.com

ವಂದನೆಗಳೊಂದಿಗೆ,

ತಮ್ಮ ವಿಶ್ವಾಸಿ,

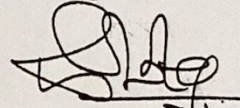

ವ್ಯವಸ್ಥಾಪಕ ನಿರ್ದೇಶಕರು

ಇವರಿಗೆ,

Principal

New Horizon College of Engineering

Outer Ring Road, Near Marathahalli

Bellandur Main Road, Bengaluru - 560 103

ಪ್ರತಿ: 1) Dr. V. Asha, Dept. of Computer Science Eng., New Horizon College of Engineering, Outer Ring Road, Near Marathahalli, Bellandur Main Road, Bengaluru - 560 103.

2) ಡಾ|| ಎಸ್. ಜಿ. ಶ್ರೀಕಂಠೇಶ್ವರ ಸ್ವಾಮಿ, ಸಮಾಲೋಚಕರು, ವಿಜ್ಞಾನ ಮತ್ತು ತಂತ್ರಜ್ಞಾನ ದಾರ್ಶನಿಕ ಸಮೂಹ, 7ನೇ ಮಹಡಿ, 4ನೇ ಹಂತ, ಬಹುಮಹಡಿ ಕಟ್ಟಡ, ಬೆಂಗಳೂರು- 560 001

भारतीय स्टेट बैंक
State Bank Of India

(40463) - RAMANASHREEARCBANASHANKARIISTG
PB NO 7079 21ST MAIN OPP B D A COMPLEX
BANASHANKARI II STG, BLORE 560070
Tel: 80-26718758 IFS Code : SBIN0040463

केवल 3 महीने के लिए वैध / VALID FOR 3 MONTHS ONLY
17092018
D D M M Y Y Y Y

PAY Principal, NHCE

या धारक को OR BEARER

रुपये RUPEES Two Lakh Only

अदा करें ₹ 2,00,000/-

खा. सं. 64110830474
A/c No.

VALID UPTO ₹ 10 LACS AT NON-HOME BRANCH

SB ACCOUNT

PREFIX:
1515500083

[Signature]
MANAGING DIRECTOR, KARNATAKA SCIENCE AND
TECHNOLOGY PROMOTION SOCIETY

MULTI-CITY CHEQUE Payable at Par at All Branches of SBI

Please sign above

⑈005978⑈ 560002380⑈ 010137⑈ 31

06/10/18 4/10/18

Karnataka SC & Tech Promotion Society

21864 CS Dept



NEW HORIZON COLLEGE OF ENGINEERING

Autonomous College Permanently Affiliated to VTU, Approved by AICTE & UGC
Accredited by NAAC with 'A' Grade, Accredited by NBA

UTILIZATION CERTIFICATE

PROGRAM NAME : FACULTY DEVELOPMENT PROGRAMME

Project Title : "DATA ACQUISITION & CONTROL SYSTEM"

SI No.	Details	Amount
1	Previous Year balance (Opening Balance (OB), if any)	NIL
2	Grants received	2,00,000.00
3	Cheque No.& Date	005978 & 17.09.2018
4	Bank Interest (if any)	NIL
5	Total available grants (1+2+3)	2,00,000.00
6	Actual Grants utilized (Statement of Expenditure enclosed)	2,37,500.00
7	Unspent Balance (4-5)	NIL
8	Excess Expenditure supported by Management	37,500.00

Certified that Rs.2,00,000/- of grant-in-aid under (Program Name Faculty Development Program) was released by Karnataka Science & Technology Promotion Society (KSTEPS) in favor of New Horizon College of Engineering vide letter No.KSTePS/VGST/FDP-Eng./2017-18/FDP-02/71/2018-19 as stated above during the year 2019. The above grant was sanctioned towards Project Title". Out of sanctioned grants, a sum of Rs.2,37,500/- (Rupees Two Lakhs Thirty Seven Thousand Five Hundred only) has been utilized for the purpose of which it was sanctioned and Rs.0/- remained unutilized at end of the financial year 2019 to be carried forward (if the program is continued) or to be refunded (if the program is completed), whichever the case is applicable. Expenditure incurred for the purpose for which the grant was sanctioned is verified with the vouchers produced before me.

Certified that I have satisfied myself that the conditions on which the grant-in-aid was sanctioned have been fulfilled and that I have exercised the following checks to see that the money was actually utilized for the purpose for which is was sanctioned.

Head of the Department
Department of Computer Applications (MCA)
NEW HORIZON COLLEGE OF ENGINEERING
Signature and Address of
The Project Coordinator

Signature of the Head of Institution and Seal
Sr. Executive Director - Accounts & Finance

SRASAL & CO
CHARTERED ACCOUNTANTS
Signature with Seal
Chartered Accountant
(FRN: & M.No)



Karnataka Science and Technology Promotion Society
Dept. of Information Technology, Bio Technology and Science & Technology, GoK
"Vijnana Bhavan", 3rd Floor, #24/2, 21st Main Road, Banashankari 2nd Stage, Bangalore-70
Ph/fax : 080-26711166, E-mail : ksteps.dst@gmail.com

Dr. H. Honne Gowda
Special Director (Technical),
Dept. of IT, BT and S&T/ Managing director, KSTePS

No. KSTePS/VGST-RGS/F/GRD No.702/2017-18

Date: 27.08.2018

Dear Sir/Madam,

Sub: Intimation of selection of RGS/F Project under the VGST scheme -reg.

Greetings from KSTePS, Dept. of Information Technology, Biotechnology and Science and Technology!!

We are pleased to inform you that the RGS/F Engineering program titled "Poly vinyl alcohol/Graphene (PVA-GO) nanocomposites-, Antimicrobial, Antifungal Studies for Food Packaging applications" submitted under the VGST scheme for the Financial Year 2017-18 has been approved by the Government based on the recommendations of Vision Group on Science and Technology under the Chairmanship of Prof. CNR Rao, Honorary President, JNCASR. You may kindly initiate necessary action for organization of the program at the earliest.

Please provide the cheque in favour address of your Institution, for releasing the sanctioned grants.

I want to personally thank you for being selected as one of the VGST program members and we wish you a great success in organization of the program.

Thanking You,

Yours sincerely,

Managing Director

To,
The Principal
New Horizon College of Engineering
Outer Ring Road, Panathur (P)
Near Marathahalli
Bengaluru - 560 103

- CC:** 1. Prof. Prashanth. K.S, Department of Physics, New Horizon College of Engineering, Outer Ring Road, Panathur (P), Near Marathahalli, Bengaluru - 560 103 - **RGS/F Grantee.**
2. Consultant, Vision Group on Science and Technology, KSTePS, Dept. of IT, BT and S&T Karnataka Government Secretariat, Room No. 702, 7th Floor, 4th Gate, M. S. Building Dr. Ambedkar Veedhi, Bangalore- 560 001.

Release of UBA funds for developmet and customization of technology

4 messages

Unnat Bharat Abhiyan <unnatbharatabhiyaniitd@gmail.com> Tue, Jan 8, 2019 at 12:33 PM
To: dhrubaghy@yahoo.com, Arkendu Chatterjee <principalbcpsr@gmail.com>, Sudarsan Reddy <suda1983@gmail.com>, shridhar kumbhar <shridhar.kumbhar@nitindia.edu>, pic_ub@iitp.ac.in, RMK Principal <principal@rmkec.ac.in>, Sujatha peela <drpsujatha@gmail.com>, Principal IGCMT <principaligcmt@rediffmail.com>, "Dr. B. Prabasheela" <prabasheela@avit.ac.in>, poonam sharma <khushi12.p@gmail.com>, Latesh Bhagat <latesh.bhagat@gov.in>, UBA PSGRKC <uba@psgrkc.ac.in>, Ramesh Arora <aroraram@gmail.com>, Binu Palarayil <binupalara1976@gmail.com>, Pro Vice-Chancellor Sathyabama Institute of Science & Technology <provc@sathyabama.ac.in>, "Dr. Bandaru Sarva Rao" <sarvarao@gmail.com>, "Dr. Velmurugan.PS, Associate Professor, Dept. of Commerce" <velmu...gan@cutn.ac.in>, Smita Harwani <smita.harwani@gmail.com>, Thomas John <thomas.john@vjec.ac.in>, ujwala belorkar <ujwalaheiorkar@rediffmail.com>, "Dr. Baidyanath Prajapati" <hodhumanities@jssaten.ac.in>, slaec principal <principalslaec@gmail.com>, Victor Paul <victor.paul@christuniversity.in>, Rita Dewanjee <rita@matsuniversity.ac.in>, Rajeev Kumar <rajeevkumar@bitmesra.ac.in>, Dean Rai <karuppusami.g@sece.ac.in>

Dear Sir/ Madam

I hope you have received the funds of Rs 1.0 lakh for selection of each technology and 0.50 lakh for customization of each solution by NEFT electronic funds transfer from IIT Delhi under the UBA program. The details of Institution, account number of institutions, UTR number and date of funds transferred are attached here for your kind information. Kindly acknowledge the same and mention the date of transfer of funds in your reply email. The expenditure head of released funds will be sent as soon as possible.

With Regards,

Dr. Ashish Ranjan (UBA Office)

On behalf of

Dr. Virendra K Vijay

National Coordinator - Unnat Bharat Abhiyan

IREDA Chair Professor & Head

Centre for Rural Development and Technology

Indian Institute of Technology Delhi

Gate No. 1, Khas, New Delhi - 110016

Phone: +91 11 26591157, 26591121

Email: unnatbharatabhiyaniitd@gmail.com, vkvijay@dat.iitd.ac.in

Webpage: http://unnat.iitd.ac.in/index.php/en/

Funds transfer details of Technology Development and customization proposal selected under the UBA program.pdf 301K

Tue, Jan 8, 2019 at 12:49 PM

Dr. Bandaru Sarva Rao <sarvarao@gmail.com>
To: Unnat Bharat Abhiyan <unnatbharatabhiyaniitd@gmail.com>
Cc: dhrubaghy@yahoo.com, Arkendu Chatterjee <principalbcpsr@gmail.com>, Sudarsan Reddy <suda1983@gmail.com>, shridhar kumbhar <shridhar.kumbhar@nitindia.edu>, pic_ub@iitp.ac.in, RMK Principal <principal@rmkec.ac.in>, Sujatha peela <drpsujatha@gmail.com>

Principal IGCMT <principaligcmt@rediffmail.com>, "Dr. B. Prabasheela" <prabasheela@avit.ac.in>, poonam sharma <khushi12.p@gmail.com>, Latesh Bhagat <latesh.bhagat@gov.in>, UBA PSGRKC <uba@psgrkc.ac.in>, Ramesh Arora <arcorame@gmail.com>, Binu Palarayil <binupalara1976@gmail.com>, Pro Vice-Chancellor Sathyabama Institute of Science & Technology <provc@sathyabama.ac.in>, "Dr. Velmurugan.PS, Associate Professor, Dept. of Commerce" <velmurugan@cutn.ac.in>, Smita Harwani <smiita.harwani@gmail.com>, Thomas John <thomas.john@vjec.ac.in>, ujjwala belorkar <ujwalabelorkar@rediffmail.com>, "Dr. Baidyanath Prajapati" <hodhumanities@jssaten.ac.in>, slaec principal <principalslaec@gmail.com>, Victor Paul <victor.paul@christuniversity.in>, Rita Dewanjee <rita@matsuniversity.ac.in>, Rajeev Kumar <rajeevkumar@bitmesra.ac.in>, Dean R&I <karuppusami.g@sece.ac.in>

Dear Sir,
We have received fund.
Thank you for your encouragement and Support..

"Simplicity is Beautiful"
"Don't React-Do Respond"
With Best Regards,
Dr.B.Sarva Rao
Mob:9666375998

[Quoted text hidden]

Smita Harwani <smiita.harwani@gmail.com>
To: Sheelan Misra <sheelan@gmail.com>

Tue, Jan 8, 2019 at 12:53 PM

For your kind information
[Quoted text hidden]

 Funds transfer details of Technology Development and customization proposal selected under the UBA program.pdf
301K

Smita Harwani <smiita.harwani@gmail.com>
To: Unnat Bharat Abhiyan <unnatbharatabhiyaniitd@gmail.com>

Thu, Jan 17, 2019 at 1:26 PM

Dear Sir we have received the funds on 1/1/19

Regards,
Dr. Smita Harwani

On Tue, Jan 8, 2019 at 12:34 PM Unnat Bharat Abhiyan <unnatbharatabhiyaniitd@gmail.com> wrote:
[Quoted text hidden]

KARNATAKA STATE COUNCIL FOR SCIENCE AND TECHNOLOGY

Indian Institute of Science Campus, Bengaluru – 560 012

Website: <http://www.kscst.iisc.ernet.in/spp.html> || Email: spp@kscst.iisc.ernet.in || Phone: 080-23600978

42nd Series of Student Project Programme: 2018-19

List of Projects Sanctioned Under Stream A - Further Development

17. NEW HORIZON COLLEGE OF ENGINEERING, BENGALURU

Sl. No.	PROJECT REFERENCE NO.	PROJECT TITLE	BRANCH	DEGREE	NAME OF THE GUIDE	NAME OF THE TEAM LEADER	TOTAL (in Rs.)
1.	42S_BE_1071	GUNDIGALA PATTE HACCHUVIKE™ - ANDROID BASED APPLICATION TO DETECT POTHOLES AND UNEVEN ROADS IN THE BENGALURU	INFORMATION SCIENCE AND ENGINEERING	BE	Dr. R J ANANDHI	Mr. ROSHAN KUMAR GUPTA	8000.00
2.	42S_BE_1101	DESIGN AND FABRICATION OF HUMAN EXOSKELETON TO ACHIEVE EASE DURING MOVEMENT	MECHANICAL ENGINEERING	BE	Mr. VINOD KUMAR G S	Mr. VIJAY SURYA V	8000.00

Note:

1. The sanctioned amount will be sent by KSCST to the College by crossed Cheque in the name of the Principal.
2. The evaluation of above projects will be conducted in the Nodal Centre in the month of May / June 2019. During nodal centre evaluation projects will be selected for state level Seminar & Exhibition which will be conducted during July / August 2019.
3. After completion of the projects, the hard copy of the report and soft in .pdf format needs to be sent to KSCST without fail.

KARNATAKA STATE COUNCIL FOR SCIENCE AND TECHNOLOGY

Indian Institute of Science Campus, Bengaluru – 560 012
 Website: <http://www.kscst.iisc.ernet.in/spp.html> || Email: spp@kscst.iisc.ernet.in || Phone: 080-23600978

42nd Series of Student Project Programme: 2018-19

List of Projects Sanctioned Under Stream C

77. NEW HORIZON COLLEGE OF ENGINEERING, BENGALURU

Sl. No.	PROJECT REFERENCE NO.	PROJECT TITLE	BRANCH	DEGREE	NAME OF THE GUIDE	NAME OF THE TEAM LEADER	TOTAL (in Rs.)
1.	42S_BE_1084	TO DESIGN AND FABRICATE A MACHINE TO CLEAN THE SLOPE SURFACES IN STEP FARMING WITH PROPER FINISH.	MECHANICAL ENGINEERING	BE	Prof. KAMALASHISH DEB	Mr. HIMALAYA BHATTA	7000.00
2.	42S_BE_1089	DESIGN AND FABRICATION OF SOLAR POWERED FLOATING WASTE COLLECTOR	MECHANICAL ENGINEERING	BE	Prof. VINAY D R	Mr. BISHAK NATH	7000.00
3.	42S_BE_1097	INSULIN STORAGE FREEZER USING THERMOELECTRIC DEVICES AND WATER COOLING	MECHANICAL ENGINEERING	BE	Prof. RONALD REAGON	Mr. AVINASH VISHWAKARMA	6000.00
4.	42S_BE_1098	EFFECT OF HEAT TREATMENT ON MECHANICAL PROPERTIES OF Cu ₃₀ Ni ₅ Zn (COPPER, NICKEL (30%) AND ZINC (5%) ALLOYS	MECHANICAL ENGINEERING	BE	Mr. KARTHIK S.N	Mr. DILIP KUMAR T	6000.00
5.	42S_BE_1099	DESIGN AND FABRICATION OF MULTIPURPOSE MACHINE FOR AGRICULTURAL PURPOSE	MECHANICAL ENGINEERING	BE	Prof. PAVAN.P.KADOLE	Mr. SURE SRINIVASULU	6500.00
6.	42S_BE_1100	DESIGN AND FABRICATION OF AUTOMATIC VACUUM OPERATED CHALK DUST COLLECTOR.	MECHANICAL ENGINEERING	BE	Mr. HANAMATH Y	Mr. KEERTHISAGAR S REDDY	6000.00
7.	42S_BE_1104	FABRICATION OF 3 AXIS PNEUMATIC TRAILER LIFT	MECHANICAL ENGINEERING	BE	Prof. RAGHU TILAK REDDY M.	Mr. MOHAMMED RIYAZ	6000.00
8.	42S_BE_1105	DESIGN AND FABRICATION OF SEPRATION OF WASTE GARBAGE USING SMART CRUSHER	MECHANICAL ENGINEERING	BE	Prof. CHETAN KUMAR D.S.	Mr. NAVNATH	5000.00
9.	42S_BE_1106	HYBRID SOLAR WINDMILL	MECHANICAL ENGINEERING	BE	Mr. MANJESH	Mr. JOHN PAUL RAJ S	6000.00
10.	42S_BE_1107	FABRICATION OF AUTOMATIC SEWAGE CLEANING MACHINE	MECHANICAL ENGINEERING	BE	Prof. VEERESHA G.	Mr. TEJAS M.	7000.00
11.	42S_BE_1643	DESIGN, ANALYSIS AND RAPID PROTOTYPING OF INSTRUMENTATION PROBE FOR AERO ENGINE APPLICATION	MECHANICAL ENGINEERING	BE	Mr. PUNEETH H V	Mr. ROHITH CHANDRASEKAR	5500.00
12.	42S_BE_1644	DESIGN AND UTILIZATION OF SOLAR INDUCED CONVECTIVE FLOW FOR POWER GENERATION USING SOLAR UPDRAFT TOWER	MECHANICAL ENGINEERING	BE	Prof. BOPANNA K D	Mr. ABHAY A PAI	6000.00

13.	42S_BE_1654	PLASTIC WASTE MANAGEMENT USING MICRO ALGAL INTEGRATED PYROLYTIC BIOREACTOR	BIOTECHNOLOGY	BE	Dr. ASHA B M	Ms. ANKITHA JOHNAS	6000.00
14.	42S_BE_1655	EXPERIMENTAL STUDY ON FUEL FILTER COATED WITH NANOPARTICLES	AUTOMOBILE ENGINEERING	BE	Prof. SMITHA B S	Mr. PRABHAKAR S	6000.00
15.	42S_BE_1860	UNDERWATER IMAGE ACQUISITION USING REMOTELY OPERATED UNDERWATER VEHICLE AND CLOUD BASED REMOTE ACCESS	ELECTRONICS AND COMMUNICATION ENGINEERING	BE	Dr. SANJEEV SHARMA	Mr. MOHAMMED SHABAZ	8000.00
16.	42S_BE_3098	DEVELOPMENT OF UNDERWATER REMOTELY OPERATED VEHICLE FOR DROWNED HUMAN BODY DETECTION	ELECTRONICS AND COMMUNICATION ENGINEERING	BE	Mr. NAVEEN H	Mr. PRASANNA KUMAR D	7000.00

Note:

1. The sanctioned amount will be sent by KSCST to the College by crossed Cheque in the name of the Principal.
2. The evaluation of above projects will be conducted in the Nodal Centre in the month of May / June 2019. During nodal centre evaluation projects will be selected for state level Seminar & Exhibition which will be conducted in the month of July / August 2019.
3. After completion of the projects, the hard copy of the report and soft in .pdf format needs to be sent to KSCST without fail.

All India Council for Technical Education

(A Statutory body under Ministry of HRD, Govt. of India)
Nelson Mandela Marg, Vasant Kunj, New Delhi-110070 Website: www.aicte-india.org



STTP- Sanction Letter

Ref. No. 34-65/292/RIFD/STTP/Policy-1/2018-19

Date _____

To

The Drawing and Disbursing Officer,
All India Council for Technical Education,
Nelson Mandela Marg,
Vasant Kunj, New Delhi - 110070

Sub: Release of grant for conduct of Short Term Training Programme (STTP) under AQIS 2018-19 during the financial year 2019-20- reg.

Sir,

This is to convey the sanction of the Council for payment of **Rs. 250000 /- (Rupees Two Lakh Fifty Thousand Only)** for conduct of Short Term Training Program as per details given below:-

1.	Name and address of the beneficiary University / Institution	NEW HORIZON COLLEGE OF ENGINEERING (E&T) , RING ROAD, NEAR MARATHALLI, BELLANDUR POST, KADUBHISANAHALLI BANGALORE URBAN-560103 Karnataka
2.	Permanent ID of Institute	1-11989651
3.	Institute type	Unaided - Private
4.	Name of Coordinator	Dr. SUJITHA S
5.	Amount sanctioned	Rs. 250000/-
6.	Amount to be released	Rs.250000/- Full & final payment
7.	Head of account	601.15(a) Gen. Short Term Training Programme (Plan)
8.	The authorized officer in whose favour Cheque/ Demand Draft/ RTGS is to be made	REGISTRAR / DIRECTOR / PRINCIPAL
9.	Title of the programme	IOT IN RENEWABLE ENERGY RESOURCES INTEGRATION TO ELECTRICITY GRID.

1. The amount of the grant shall be drawn by the Drawing and Disbursing Officer, All India Council for Technical Education on the grant-in-aid bill and shall be disbursed to and credited to the Registrar/ Director/Principal of the institute through RTGS.

2. This grant-in-aid is being released in conformity with the terms & conditions as well as norms of the scheme as already communicated, and also being communicated in this letter.
3. The Principal of the Institute and the Coordinator of the Program are requested to verify the correctness of the under-mentioned Bank Account / RTGS Details submitted by them alongwith the proposals, in which the grant is being released:-

Institute PAN No.	Bank Name	Bank Branch Name	Bank Branch Address	Account Holder Name	Account Type	Account Number	IFSC Code
AAATN3061E	INDIAN BANK	NHCE Branch	Ring Road, Kadubeesanahalli, Near Marathalli, Bangalore - 560016	New Horizon College of Engineering	Current account	484700078	IDIB000N112

Instructions/Guidelines to be followed by the University/Institution

I. Disbursement of funds to University/Institutions

- a. The full amount of the grant sanctioned is being released as advance to the University/Institute.
- b. The amount spent by the institute on the conduct of STTP shall be adjusted on the basis of utilization certificate and detailed expenditure statement submitted by the University/Institution on the prescribed format along with other mandatory documents viz feedback form, copy of proceedings and completion report etc.
- c. The above said amount of grant shall be refunded back to AICTE if the Letter of Approval (LOA) / Extension of Approval (EOA) is not issued by AICTE to the institute for the academic year 2019-20.

II Maintenance of Accounts

- a. The Institute shall strictly follow the provisions laid down in the scheme document as available on the portal.
- b. Funds covered by this grant shall be kept separately and would not be mixed up with other funds so as to know the amount of interest accrued on the grant.
- c. The University/College/Institute shall maintain proper accounts of the expenditure out of the grants, which shall be utilized only on approved items of expenditure.
- d. The grant is intended to cover items of expenditure connected with the Short Term Training Programme such as Boarding & Lodging to the participants, TA to outstation participants, Honorarium to Course Coordinator, reading material to participants, Honorarium to resource persons, TA/DA to resource persons including two outstations resource persons & working expenses (reprographic services, postage, transport, daily wages, tea/coffee etc.

III. Conduct of test and issuance of certificate

A test shall be conducted by Program Evaluation Committee (PEC) at the end of the program and the certificates shall be issued to those participants who have attended the program and have qualified in the test.

IV. Submission of Documents by the University/Institutions to AICTE

- a. The following mandatory relevant documents are required to be submitted by the University/Institution within one month of the completion of the program:-

- (i) Original Statement of actual expenditure & Utilization Certificate in the prescribed proforma duly signed by the Head of the institution and countersigned by Registrar/Finance Officer/Govt. Auditor. In case of self-financing/private institutions, Statement of actual Expenditure & Utilization Certificate are required to be audited & signed and sealed by a Chartered Accountant endorsing the membership number and complete postal address. Format for the same is available on AICTE web portal.

The University/Institution is not required to submit bills/vouchers/invoices etc for the expenditure incurred out of recurring grants. However, such copies of bills/vouchers/invoices shall be digitized by respective institutions receiving grant and uploaded scanned copies of such bills/vouchers/invoices etc on the portal for availability and view at any point of time.

- (ii) Feedback form in the prescribed proforma.
(iii) Copy of the proceedings and completion report.
(iv) List of candidates who have successfully completed the program on the basis of the test conducted by Program Evaluation Committee (PEC).
(v) Report submitted by Program Evaluation Committee (PEC).
- b. The amount of the grant shall be adjusted on submission of utilization certificate & detailed expenditure statement by University/Institution. On receipt of these documents, the total amount of financial assistance, admissible as per the norms, shall be worked out and grant-in-aid adjusted.

V. General instructions

- a. Preferably 10% of the participants may be industry professionals deputed by industry. Further, not more than 2 participants shall be from the host institution/group of institutions.
- b. Money to be reimbursed on the grant (for any reasons to include unspent amount, interest, penalty if imposed) shall be refunded back to AICTE in the form of Demand Draft payable to Member Secretary, AICTE, New Delhi.
- c. As AICTE needs adequate time for depositing the Demand Draft in the bank, the same be immediately dispatched to avoid any lapse of the validity period.
- d. The STTP is a residential program of a duration of six days with minimum 40 participants. The approved STTP shall be conducted within three months from the date of release of funds.
- e. If programme is not conducted in the period of three months of the issuance of this Sanction Order, the released amount, alongwith interest accrued thereon, has to be necessarily returned back to AICTE within a month.
- f. The expenditure under the Heads 'Honorarium to Course Coordinator' and 'Honorarium to Resource Persons' shall not exceed 1% & 20% respectively of

the total sanctioned grant for the Programme. However, overall expenditure shall not exceed the funds sanctioned for the Programme.

- g. Any extra money required to complete the programme must be borne by the institute from their own resources. But the quality of the activities should not be compromised.
- h. Any unavoidable circumstantial change in the program with respect to name of Project Coordinator, Venue and date for organizing STTP would mandatorily require prior approval of the Council. All such requests should be addressed to AICTE, in advance, recording the specific reasons for proposed changes, failing which the offer for the grant already issued would be treated as automatically withdrawn and the financial assistance released in favour of the beneficiary institution shall be refunded immediately to the Council. Kindly mention the File No. 34-65/292/RIFD/STTP/Policy-1/2018-19 in your future correspondence.
- i. **Program Evaluation Committee (PEC)** is required to be constituted at institutional level. The constitution of the PEC shall be as under:
- Principal/Director/Registrar of the institution (Chairperson).
 - Coordinator of the program (Member Secretary).
 - Two HoDs and one subject expert (members).

The members of the said PEC shall not be below the rank of Associate Professor. A test shall be conducted by Program Evaluation Committee (PEC) at the end of the program and the certificates shall be issued to those participants who have attended the program and have qualified in the test. The minutes of the meetings, along with PEC report, are to be submitted to the Council at end of the program along with other mandatory documents.

- j. **GoI GFR rules** (@<https://doe.gov.in/order-circular/general-financial-rules2017-0>) should be followed during utilization of grant.
- k. This Sanction Order may be treated as Offer Letter for all purposes.

NOTE:- Any deviation from the above will invoke serious action against the Institute.

Yours sincerely,

(Dileep N Malkhede)
Advisor-I (RIFD)

Copy forwarded for information and necessary action to:-

- Name and Address of the Coordinator**
Dr. SUJITHA S
NEW HORIZON COLLEGE OF ENGINEERING (E&T)
RING ROAD, NEAR MARATHALLI, BELLANDUR POST, KADUBHISANAHALLI
BANGALORE 560103 Karnataka
- The Registrar / Director / Principal**
NEW HORIZON COLLEGE OF ENGINEERING (E&T)
RING ROAD, NEAR MARATHALLI, BELLANDUR POST, KADUBHISANAHALLI
BANGALORE 560103 Karnataka
- Guard File**

12 DEC 2019



Phone : 011-26131577 - 78, 80
011-29581000
Website : www.aicte-india.org



सत्यमेव जयते

अखिल भारतीय तकनीकी शिक्षा परिषद्

(भारत सरकार का एक संविधिक निकाय)
(मानव संसाधन विकास मंत्रालय, भारत सरकार)
नेल्सन मंडेला मार्ग, वसंत कुंज, नई दिल्ली-110070

ALL INDIA COUNCIL FOR TECHNICAL EDUCATION

(A Statutory Body of the Govt. of India)
(Ministry of Human Resource Development, Govt. of India)
Nelson Mandela Marg, Vasant Kunj, New Delhi-110070

(3)

Dr. Uma Raghunathan
Director (RIFD)

F No. 65-12/RIFD/SPDP/POLICY-1/2016-17
Dated: 20.09.2019

To

Principal,
New Horizon College of Engineering (E & T),
Ring Road, Near Marathalli, Bellandur-Post,
Kadubhisanaahalli, Urban Bangalore,
Karnataka-560103

Dean R&D

Dr. Sheel Mishra HOD
- MBA -

Sub: Release of 2nd installment of Rs. 6,25,000/- under Skill & Personality Development Programme Centre for SC/ST student (SPDP)-reg.

Sir,

This has a reference to your letter dated-13.06.2019, forwarding therewith the details of infrastructure created by the College for the Centre, details of items purchased, audited Utilization Certificate, Statement of Expenditure, Receipt and payment account and copies of asset register in respect of 1st installment of Rs. 12,50,000/- released for incurring expenditure under non-recurring and recurring head.

On scrutiny of the documents, it has been found that College has requested to release 2nd installment of Rs. 6,25,000/- to incur the expenditure under Non-recurring and recurring head. Ongoing through the Utilization Certificate and Receipt and Payment, it was noticed that Institution has unspent balance and accrued interest as shown in the table below:-

Particulars of release	Non-Recurring	Recurring	Total
1. Grant released as 1 st Installment	Rs. 10,62,500/-	Rs. 1,87,500/-	Rs. 12,50,000/-
2. Expenditure incurred	Rs. 14,62,736/-	Rs. 62,818/-	Rs. 15,25,554/-
3. Amount incurred in excess of release from Institute own resources/Unspent amount available	Rs. 4,00,236/- (Excess exp.)	Rs. 1,24,682/- (unspent amount available with the institute)	Rs. 1,24,682/-
5. Interest earned	Rs. 37,534/-		Rs. 37,534/-

Excess expenditure of Rs. 4,00,236/- is to be met by the College from its own resources.

In view of the above, you are requested to refund the unspent and interest amount of Rs. 1,62,216/- (124682+37534) along with accrued interest thereon till September-2019 by way of demand draft in favor of Member-Secretary, AICTE, New Delhi payable at New Delhi along with above mentioned documents for considering the release of 2nd installment of grant-in-aid.

Yours Sincerely

(Uma Raghunathan)

Copy for information to:

- Dr. Sheelan Mishra
Department of Management
New Horizon College of Engineering (E & T),
Ring Road, Near Marathalli, Bellandur-Post,
Kadubhisanaahalli, Urban Bangalore,
Karnataka-560103

2958-
-1310



Dated: 10 May 2019

F. No. 34-55/60/RIFD/FDP/Policy-1/2017-18

All India Council for Technical Education

(A Statutory body under Ministry of HRD, Govt. of India)
Nelson Mandela Marg, Vasant Kunj, New Delhi-110070 Website: www.aicte-india.org



FDP - Sanction Letter

To

The Drawing and Disbursing Officer,
All India Council for Technical Education,
Nelson Mandela Marg,
Vasant Kunj,
New Delhi - 110070

Sub: Release of a sum of Rs 318000 /- for conduct of Faculty Development Programme (FDP) - reg.

Sir,

This is to convey the sanction of the Council for payment of Rs. 318000 /- (Rupees Three Lakh Eighteen Thousand Only) for conduct of FDP on Faculty Development Program on High Performance, Grid and Cloud Computing (HGCC) to NEW HORIZON COLLEGE OF ENGINEERING (M & T), BANGALORE URBAN, Pin No- 560103, Karnataka, under the Scheme of Faculty Development Programme.

1. The amount of the grant shall be drawn by the Drawing and Disbursing Officer, All India Council for Technical Education on the grant-in-aid bill and shall be disbursed to and credited to the Registrar/ Director/Principal of the institute through RTGS.
2. This grant-in-aid is being released in conformity with the terms & conditions as well as norms of the scheme as already communicated, and also being communicated in this letter.
3. The sanctioned amount is debitible to the Major Head 602.6(a) Gen. of the Scheme of Faculty Development Programme and is valid for payment during the financial year 2019-20.

The instructions/guidelines to be followed by University/Institution

1. Release of funds and maintenance of accounts

- a. The Principal of the institute and the Coordinator of the program are requested to verify the correctness of the under mentioned bank account/ RTGS details submitted by them along with the Proposal, in which the grant is being released:

Institute PAN No.	Bank Name	Bank Branch Name	Bank Branch Address	Account Holder Name	Account Type	Account Number	IFSC Code
AAATN3061E	INDIAN BANK	NEW HORIZON COLLEGE OF ENGINEERING	BANGALORE	NEW HORIZON COLLEGE OF ENGINEERING	Current Account	484700078	IDIB00ON112

In case of any omission the same should be reported to AICTE immediately

- b. The Institute shall strictly follow the provisions laid down in the scheme document and sanction order no. F. No. 34-55/60/RIFD/FDP/Policy-1/2017-18 dated 10.05.2019 issued by this office.
- c. Funds covered by this grant shall be kept separately and would not be mixed up with other funds so as to know the amount of interest accrued on the grant.
- d. The University/College/Institute shall maintain proper accounts of the expenditure out of the grants, which shall be utilized only on approved items of expenditure.
- e. The grant is intended to cover items of expenditure connected with the Faculty Development Programme such as Boarding & Lodging to the participants, TA to outstation participants, Honorarium to Course Coordinator, reading material to participants, Honorarium to resource persons, TA/DA to resource persons including two outstations resource persons & working expenses (reprographic services, postage, transport, daily wages, tea/coffee etc).

Dated: 10 May 2019

- f. The FDP will be organized for 2 weeks with minimum 40 participants. The approved FDP shall be conducted within nine months from the date of release of funds
- g. Any unavoidable circumstantial change in the Program with respect to name of Project Coordinator, Venue and date for organizing FDP would mandatorily require prior approval of the Council. All such requests should be addressed to AICTE, in advance, recording the specific reasons for proposed changes, failing which the offer for the grant already issued would be treated as automatically withdrawn and the financial assistance released in favour of the beneficiary institution shall be refunded immediately to the Council. Kindly mention the File No. 34-55/___/RIFD/FDP/Policy-1/2017-18 in your future correspondence.
- h. **Program Evaluation Committee (PEC)** is required to be constituted at institutional level. The constitution of the PEC shall be as under:
- Principal/Director/Registrar of the institution (Chairperson),
 - Coordinator of the program (Member Secretary),
 - Two HODs and one subject expert (members)
- The members of the said PEC shall not be below the rank of Associate-Professor. A test shall be conducted by Program Evaluation Committee (PEC) at the end of the program and the certificates shall be issued to those participants who have attended the program and have qualified in the test. The minutes of the meetings, along with PEC report, are to be submitted to the Council at end of the program along with other mandatory documents
- i. GOI GFR rules (@<https://doe.gov.in/order-circular/general-financial-rules2017-0>) should be followed during utilization of grant.
- j. This Sanction Order may be treated as Offer Letter for all purposes.

Yours sincerely,

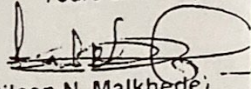
 (Dileep N. Malkhede)
 Advisor-I (RIFD)

28/6/19

Copy forwarded for information and necessary action to: -

1. Coordinator of the Program

Dr. ASHA V
 NEW HORIZON COLLEGE OF ENGINEERING (M & T)
 RING ROAD, NEAR MARATHALLI,
 KADUBHISANAHALLI,
 BELLANDUR POST BANGALORE URBAN
 BANGALORE - 560103

2. The Registrar / Director / Principal

NEW HORIZON COLLEGE OF ENGINEERING (M & T)
 RING ROAD, NEAR MARATHALLI,
 KADUBHISANAHALLI,
 BELLANDUR POST BANGALORE URBAN
 BANGALORE - 560103

3. Guard File

Institute Name

New Horizon College of Engineering, Ring Road, Near Marathalli,
Bangalore - 560 103, INDIA
PHONE: +91-80-6629 7777
FAX: +91-80-2844 0770
WEBSITE: <http://newhorizonindia.edu/nhengineering/>

DATE 22/2/2019
INVOICE #
CUSTOMER ID
DUE DATE

PM - YUVA YOJANA, NATIONAL E-HUB
NIESBUD, 1ST FLOOR, NIESBUD, A-23
SECTOR - 62, INSTITUTIONAL AREA
NOIDA - 201309, U.P. (INDIA)
PHONE - 0120 - 4017095/96/97

DESCRIPTION	Unit Cost	NOS	
1 Training Cost:			
Nos. of E-Leader Training Participated	6,666.67	1	6,666.67
Nos. of Faculty Facilitator Training Participated	6,666.67	1	6,666.67
No. of Faculty Mentor Training Participated	6,666.66	-	-
2 Honorarium:			
Pre-launch activities:			
Faculty Name #1	5,000.00		
Faculty Name #2	5,000.00	2	10,000.00
Nos. of Faculty:			
Faculty #1 Course Duration in months	5,000.00		
Faculty #2 Course Duration in months	5,000.00	4	20,000.00
3 Nos. of Students who have given final assessments:		174	
Subtotal			43,333.34

OTHER COMMENTS

1. Please transfer the payment on below account:

Account Name: New Horizon College - PM YUVA
Account No.: 6581411607
IFSC Code: IDIB000N112
Current/Saving A/c: Saving A/C
Bank Name & Branch: Indian Bank, New Horizon College of Engg
Branch, Outer Ring Road, Kadubisanahalli Panathur, PO Bangalore -

Make all checks payable to
New Horizon College of Engineering

Sign & Stamp



Ref: UNITYsat/TSC SatNAV/Android MobileApp/001

24 June 2018

To

The Principal (Attention to Prof & HoD, Dept of CSE)
New Horizon College of Engineering (NHCE)
Outer Ring Road, Kadubesnahalli, Bangalore, Karnataka

Sanction of Design and Development of TSC SatNAV: Amateur Radio and Weather Satellite Tracker and Passes Predictor for Android-10 Months (2018-19)-Rs. 15,00,000/-

Dear Professor,

SUB: Sanction of Matching Grant-Joint Development- Design and Development of TSC SatNAV: Amateur Radio and Weather Satellite Tracker and Passes Predictor for Android-10 Months (2018-19)- Rs.15,00,000/- Reg.

REF: Your Project Proposal in Response to Announcement of Opportunity-Our Interactions/On-line Meetings/MoU Signed with Your Institution on 05 April 2016

Under the powers vested with Programme Office for the UNITYsat Programme as per the TSC-ITCA-CSPD Consortium which has signed MoU on 05 April 2016 and subsequent Announcement of Opportunity issued, I am directed to convey the sanction of the following project for the year 2018-19:

Title of the Project: **"Design and Development of TSC SatNAV: Amateur Radio and Weather Satellite Tracker and Passes Predictor for Android"**

Amount: **Rs. 15 Lakhs as Matching Grant**

Total estimated funds for the project is Rs.30 Lakhs. Remaining Rs.15 Lakhs will be borne by the host as its own contribution from Institution. However, the same is subject to revision based on performance and review. The break-up of the grant under various heads is given below:

Sl. No.	Head	Grant-in-Aid from TSC Technologies P Ltd	Contribution from Grantee Institution- NHCE
1.	Man Power	Nil	
2.	Equipment (Ground Station)	Rs. 2.0 Lakhs	
3.	Components for Systems and Sub-system	Rs. 2.0 Lakhs	Rs. 15 Lakhs
4.	Android Development of Software-Mobile App	Rs. 6.0 Lakhs	a) Client Computer, Antenna System, Rotator, Rotator Control Hardware/Software: Rs. 8 Lakhs
5.	Consumables (Including Maintenance)	Rs. 2.5 Lakhs	
6.	Testing and Integration Services	Rs. 2.5 Lakhs	b) Travel/Contingency/Institutional Overhead: Rs.7 Lakhs
7.	Contingency	Nil	
8.	Travel	Nil	
9.	Overheads (10%)	Nil	
	Total	Rs.15 Lakhs	Rs.15 Lakhs

Note:

@ Client Software, Radio Receiver

^On-Board Computer (Primary Computation Unit, External Memory & Secondary Housekeeping Controller)

1. Funds for second installment will be released on satisfactory progress and submission of six month progress report by PI to the Programme Office and based on recommendation with due approval of competent authority.
2. Statement of accounts and utilization certificate duly certified by the executive financial authority of the Institution is also required to be submitted along with the annual report. Excess expenditure, beyond the sanctioned amount, shall be responsibility of grantee institution.

3. The duration of the project is TEN MONTHS with review after six months! The date of receipt of the grant would be reckoned as the commencement date of the project which has to be intimated to the Programme Office without any ambiguity.
4. A separate account for the grant would be maintained by New Horizon College of Engineering and any interest earned thereon, if any, would accrue to UNITYsat Programme.
5. Unspent balance, on completion of the project should be sent by the grantee institution through a RTGS/Cheque/Draft in the name of TSC Technologies P Ltd, Bangalore for doing the needful.
6. A list of inventory of equipment purchased out of the Programme grant shall be intimated year-wise, along with its cost and source of procurement to the Programme Office.
7. On completion of the project, the grantee institution would forward the consolidated list with request, if any, for the retention of any equipment for another project or in-house R&D, with due recommendations of their executive authority and the concerned panel.
8. In case of any joint publications of Technical Research Papers related to this project as a part/outcome of the research works shall have the mentioning/acknowledgement of consortium which has granted the matching grant for the project appropriately.
9. A Closure Report alongwith copies of technical report may be submitted within sixty days of completion of project alongwith Statement-2 (Statement of Expenditure) and Statement -3 (Utilization Certificate) as per the Annexure III of Grants-in-aids rules duly audited from the Audit Authority of Institution signed in ink in duplicate.
10. TSC Technologies P Ltd, Bangalore will make disbursement of money/equivalent in kind as sanctioned.

With Warm Regards,

Yours Sincerely,



(NIKHIL RIYAZ)

Director

TSC Technologies Private Limited

M: +91 97418 96297

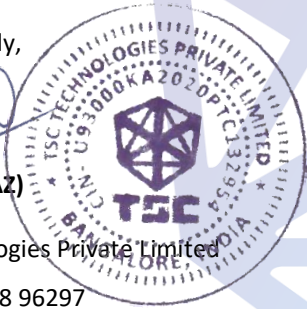

Copy to

- a) Programme Director, UNITYsat Programme Office, Bangalore
- b) President, Indian Technology Congress Association
- c) Head, Committee for Space Programme Development, Serbia
- d) Convener, 75 Students' Satellites Consortium: Mission 2022
- e) Professor and HoD, NHCE, Bangalore

Ref: CubeSat/ADSB/Indo-Israel JD/001

15 September 2016

To

The Principal (*Attention to Prof & HoD, Dept of Mech/CSE/ECE*)

New Horizon College of Engineering (NHCE)

Outer Ring Road, Kadubesnahalli,

BANGALORE, KARNATAKA

Dear Professor,

SUB: Sanction of Grant-in-Aid-Joint Development- Design and Development of CubeSat 2U; ADSB including Launch Cost; Indo-Israel Joint Development under UNISEC India (Timeline: 24 Months). Indo-Israel Joint Development- 24 Months (2017-18 & 2018-19)- Rs.26,00,000/- (Cash/Kind)- Partnering Funding Agencies: ITCA, UNISEC India, DRL, TSC P Ltd-Reg.

REF: Your Project Proposal in Response to Announcement of Opportunity-Our Interactions/On-line Meetings/MoU Signed with Your Institution on 05 April 2016

Under the powers vested with Programme Office for the Indo-Israel Joint Development Programme under UNISEC India as per the ITCA-TMIsat-UNISEC India-DRL-TSC Consortium which has signed MoU on 05 April 2016 and subsequent Announcement of Opportunity issued,

I am directed to convey the sanction of the following project for the respective years from 2017-18 & 2018-19:

Project Split-up	26,00,000/-
2017-18 (Project Split-up Among Departments)	
<i>Dept. Mech: Design and Development of Satellite Monolithic Structure, Machining, Orbital Mechanics-Calculation-Simulation</i>	4,00,000/-
<i>Dept. CSE: On Board Computer (OBC), Coding and Programming Responsibilities</i>	5,00,000/-
2018-19 (Project Split-up Among Departments)	
<i>Dept. Mech: Design and Development of Satellite Monolithic Structure, Machining, Orbital Mechanics-Calculation-Simulation</i>	5,00,000/-
<i>Dept. CSE: On Board Computer (OBC), Coding and Programming Responsibilities</i>	9,00,000/-
<i>Dept. ECE: 18 Months: CDR, HWDR, EPS, Telemetry, Onboard Systems and Subsystems, Antenna Deployment, Integration Services, Testing and Qualifications for Launch etc</i>	3,00,000/-

Terms and Conditions of Sanction of Grant-in-Aid

1. Funds for second installment will be released on satisfactory progress and submission of six month progress report by PI to the Programme Office and based on recommendation with due approval of competent authority.
2. Statement of accounts and utilization certificate duly certified by the executive financial authority of the Institution is also required to be submitted along with the annual report. Excess expenditure, beyond the sanctioned amount, shall be responsibility of grantee institution.

3. The duration of the project is TWENTY FOUR MONTHS (2 Years) with review after six months! The date of receipt of the grant would be reckoned as the commencement date of the project which has to be intimated to the Programme Office without any ambiguity.
4. A separate account for the grant would be maintained by New Horizon College of Engineering (NHCE) and any interest earned thereon, if any, would accrue to CubeSat 2U Programme.
5. Unspent balance, on completion of the project should be sent by the grantee institution through a RTGS/Cheque/Draft/in Kind in the name of ITCA/UNISEC India/TMISat/TSC Technologies P Ltd, Bangalore for doing the needful.
6. A list of inventory of equipment purchased out of the Programme grant shall be intimated year-wise, along with its cost and source of procurement to the Programme Office.
7. On completion of the project, the grantee institution would forward the consolidated list with request, if any, for the retention of any equipment for another project or in-house R&D, with due recommendations of their executive authority and the concerned panel.
8. In case of any joint publications of Technical Research Papers related to this project as a part/outcome of the research works shall have the mentioning/acknowledgement of consortium which has granted the matching grant for the project appropriately.
9. A Closure Report alongwith copies of technical report may be submitted within sixty days of completion of project alongwith Statement-2 (Statement of Expenditure) and Statement -3 (Utilization Certificate) as per the Annexure III of Grants-in-aids rules duly audited from the Audit Authority of Institution signed in ink in duplicate.
10. UNISEC India/TMISat/ITCA/TSC Technologies P Ltd, Bangalore will make disbursement of money/equivalent in kind as sanctioned.

With best regards,

Yours sincerely,



*Secretary General, Indian Technology Congress Association and UNISEC-India
Convener, 75 Students' Satellite Consortium: Mission 2022*

Copy to

- a) Programme Director, Indo-Israel Joint Development Programme Office, Bangalore
- b) President, Indian Technology Congress Association
- c) Head, TMISat, Isarel
- d) Convener, 75 Students' Satellites Consortium: Mission 2022
- e) Professor and HoDs, Mech/CSE/ECE, NHCE, Bangalore

Indian Technology Congress Association

#3, 4th Floor, First Main, BDA Layout, Kodihalli, HAL 2nd Stage, Bengaluru - 560 008.

<https://www.itca.org.in/>

KARNATAKA STATE COUNCIL FOR SCIENCE AND TECHNOLOGY

Indian Institute of Science Campus, Bengaluru – 560 012

Website: <http://www.kscst.iisc.ernet.in/spp.html> || Email: spp@kscst.iisc.ernet.in || Phone: 080-23600978

LIST OF PROJECTS SANCTIONED UNDER THE 41ST SERIES OF STUDENT PROJECT PROGRAMME: 2017-18

84. NEW HORIZON COLLEGE OF ENGINEERING, BENGALURU

Sl. No.	PROJECT REFERENCE NO.	PROJECT TITLE	BRANCH	DEGREE	NAME OF THE GUIDE	NAME OF THE TEAM LEADER	SANCTIONED AMOUNT (in Rs.)
312.	41S_BE_0052	AGUMENTING THE LIFE OF POLYMER MATERIAL USED IN 3D PRINTERS BY USING REINFORCED POLYMER MATERIAL IN FDM TECHNOLOGY	MECHANICAL ENGINEERING	BE	Dr. M.S. GANESHA PRASAD	Mr. SAMRAT BANERJEE	6000.00
313.	41S_BE_0056	SMART CONVEYANCE FOR PHYSICALLY CHALLENGED PEOPLE	MECHANICAL ENGINEERING	BE	Prof. NAGENDRA JAYARAM	Mr. SUDHARSHAN T S	6000.00
314.	41S_BE_0062	DESIGN AND FABRICATION OF AN ARTIFICIAL LEG MECHANISM FOR ABOVE KNEE AMPUTEES	MECHANICAL ENGINEERING	BE	Prof. BOPANNA K D	Mr. GANESH KUMAR C	7000.00
315.	41S_BE_0066	DESIGN AND FABRICATION OF PORTABLE SOLAR OPERATED WATER PURIFICATION UNIT	MECHANICAL ENGINEERING	BE	Mr. SUJEETH SWAMI	Mr. H. HITESH	7000.00
316.	41S_BE_0075	DESIGN AND FABRICATION OF A TADPOLE MODEL SOLAR POWERED TRICYCLE	MECHANICAL ENGINEERING	BE	Prof. VINAYAK B	Mr. DIJIN MATHEW	7000.00
317.	41S_BE_0078	DESIGN AND DEVELOPMENT OF HUMAN ARM EXOSKELETON	MECHANICAL ENGINEERING	BE	Prof. VINOD KUMAR G S	Mr. RAMAN SHARMA	6000.00
318.	41S_BE_0670	USE OF BIO-LUBRICANTS IN ATV	AUTOMOBILE ENGINEERING	BE	Mr. K.A.JAYASHEEL KUMAR	Mr. SURESH G S	5000.00
319.	41S_BE_0674	REPLACEABLE DIESEL PARTICULATE FILTER	AUTOMOBILE ENGINEERING	BE	Mr. GIRISH TILAK	Mr. SRIRAM IYER	7000.00



STUDENT PROJECT PROGRAMME : 2017 - 18
BIOFUEL PROJECTS

Compendium of
41st Series SPP : Biofuel Projects

KARNATAKA STATE COUNCIL FOR SCIENCE AND TECHNOLOGY
Indian Institute of Science Campus, Bengaluru

Supported by

KARNATAKA STATE BIOENERGY DEVELOPMENT BOARD
Department of Rural Development and Panchayath Raj, Government of Karnataka

21) MANGALORE INSTITUTE OF TECHNOLOGY AND ENGINEERING, MOOBDIDRI

Sl. No.	Proj. Ref. No.	TITLE OF THE PROJECT	BRANCH	NAME OF THE GUIDE/S	STUDENT1 & TEAM LEADER
27.	41S_B_BE_057	PERFORMANCE AND EMIS ION CHARACTERISTICS STUDIES OF CI ENGINE USING GRAPHENE AND ALUMINIUM OXIDE NANO PARTICLES BLENDED DAIRY WASTE SCUM BIO DIESEL AND EFFECT OF INJECTION PRESSURE AND THREE AND FIVE HOLE OF NOZZELE CUMBUTION PROCESS	MECHANICAL ENGINEERING	Dr. VIGNESH NAYAK	Mr. MOHAMMED SAFWAN

22) MANIPAL INSTITUTE OF TECHNOLOGY, MANIPAL

28.	41S_B_BE_099	OPTIMIZATION OF BIOGAS PRODUCTION IN SEMI BATCH REACTORS	CHEMICAL ENGINEERING	Dr. GAUTHAM JEPPI	Mr. JAYALAL J.
-----	--------------	--	----------------------	-------------------	----------------

23) NAGARJUNA COLLEGE OF ENGINEERING AND TECHNOLOGY, BENGALURU

29.	41S_B_BE_042	PILOT PLANT STUDY FOR SUSTAINABLE ENERGY GENERATION IN SEPTIC TANK USING BIO-FUEL CELL	CIVIL ENGINEERING	Dr. K.KUMAR	Mr. MAYANA ISMAIL KHAN
-----	--------------	--	-------------------	-------------	------------------------

24) NEW HORIZON COLLEGE OF ENGINEERING, BENGALURU

30.	41S_B_BE_003	EXPERIMENTAL STUDY OF ACETYLENE AND ALCOHOL AS AN ALTERNATIVE FUEL FOR GASOLINE ENGINE	MECHANICAL ENGINEERING	Dr. M S GANESH PRASAD	Mr. ZAKI AMER
31.	41S_B_BE_006	A COMPARATIVE STUDY OF THE PROPERTIES AND EFFECTS OF DIFFERENT BLENDS OF BIO-DIESEL ON CRANKCASE LUBRICANT AND PERFORM EXHAUST GAS ANALYSIS FOR THE SAME	MECHANICAL ENGINEERING	Mr. KAMALASISH DEB	Mr. AMAR KUMAR BHATT
32.	41S_B_BE_007	DESIGN AND FABRICATION OF MACHINE TO CONVERT PLASTIC INTO OIL AND GASEOUS FUEL PRODUCTION	MECHANICAL ENGINEERING	Prof. LAKSHMANA NAIK	Mr. SITAL KUMAR SAH
33.	41S_B_BE_008	IMPROVISATION ON PHYSICAL AND COMBUSTION PROPERTIES OF FUEL BRIQUETTE FROM PONGAMIA AND GLYCERIN MIXING DIFFERENT BINDERS	MECHANICAL ENGINEERING	Mr. LAKSHMINARASIMHA N	Mr. ARJUN YADAV
34.	41S_B_BE_067	A COUPLED PROCESS INTEGRATING HEAVY METAL BIOREMEDIATION AND BIODIESEL PRODUCTION USING OLEAGINOUS MICROALGAE	BIOTECHNOLOGY	Dr. R.S.UPENDRA	Ms. CHAITHANYA LAKSHMI
35.	41S_B_BE_090	DESIGN OF PYROLYSIS REACTOR FOR SYNTHESIS OF BIODIESEL FROM POULTRY WASTE (CHICKEN FEATHERS) AND ENGINE PERFORMANCE TESTING	BIOTECHNOLOGY	Mr. GIRISH N DESAI	Mr. MANAN CHAMARIA

25) NMAM INSTITUTE OF TECHNOLOGY, NITTE

36.	41S_B_BE_063	PROCESS DEVELOPMENT FOR THE PRODUCTION OF BIOETHANOL USING COFFEE BERRY PULP IN LAB SCALE AND BIOREACTOR	BIOTECHNOLOGY	Dr. C.VAMAN RAO	Ms. SHAIKH ANAMBANU AMEER
37.	41S_B_BE_103	GLYCEROL AS A FEED STOCK FOR MICROBIAL LIPID PRODUCTION	BIOTECHNOLOGY	Ms. HARSHITHA M JATHANNA	Ms. ELSA JOSSY J

26) P E S COLLEGE OF ENGINEERING MANDYA

38.	41S_B_BE_072	LOW COST AND PORTABLE SCRUBBING AND BOTTLING UNIT USING HYBRID COMPRESSOR FOR BIO FUEL SYSTEM	MECHANICAL ENGINEERING	Prof. K J MAHENDRA BABU	Mr. MANOJ T
-----	--------------	---	------------------------	-------------------------	-------------

27) R. V. COLLEGE OF ENGINEERING, BENGALURU

39.	41S_B_BE_081	PRODUCTION OF BACTERIAL CELLULOSE FROM SEWAGE AND ITS USE IN POWER GENERATION THROUGH ENZYMATIC FUEL CELL FORMULATION	BIOTECHNOLOGY	Dr. LINGAYYA HIREMATH	Ms. AISHWARYA BHAT
-----	--------------	---	---------------	-----------------------	--------------------

28) RAMAIAH INSTITUTE OF TECHNOLOGY, BENGALURU

40.	41S_B_BE_027	CHEMICAL AND ENZYMATIC CONVERSION OF BIOGLYCEROL TO ACETINS	CHEMICAL ENGINEERING	Dr. RAJESWARI M KULKARNI	Mr. SYED SAQLINE
41.	41S_B_BE_028	CATALYTIC CONVERSION OF GLYCEROL TO OXYGENATED FUEL ADDITIVE (SOLKETAL) USING HETEROPOLYACID	CHEMICAL ENGINEERING	Dr. ARCHNA	Mr. SUDARSHAN C S

F.No. 6-87/RIFD/FDP/Policy-1/2016-17

Dated: 6th June 2017

To

The Drawing and Disbursing Officer,
All India Council for Technical Education,
Nelson Mandela Marg,
Vasant Kunj,
New Delhi - 110067.

Sub: Release of a sum of Rs. 350000/- being the 1st Installment of the total Grant of Rs. 700000/- for conduct of Faculty Development Programme (FDP) during the financial year 2017-18 - reg.

Sir,

This is to convey the sanction of the Council for payment of Rs. 350000/- (Rupees Three Lakh Fifty Thousand Only) as 1st installment out of the total approved grant-in-aid of Rs. 700000/ for conduct of FDP on Research Frontiers in Advanced Networking, Security and IOT - A Tool Driven Approach to NEW HORIZON COLLEGE OF ENGINEERING (E&T), RING ROAD, NEAR MARATHALLI, BELLANDUR POST, KADUBHISANAHALLI BANGALORE URBAN Pin No - 560103 Karnataka, under the Scheme of Faculty Development Programme.

1. The amount of the grant shall be drawn by the Drawing and Disbursing Officer, All India Council for Technical Education on the grant-in-aid bill and shall be disbursed to and credited to the Registrar/ Director/Principal of the institute through RTGS.
2. This grant-in-aid is being released in conformity with the terms & conditions as well as norms of the Scheme as already communicated, and also being communicated in this letter.
3. The sanctioned amount is debitible to the Major Head 601.9(a) Gen. of the Scheme of Faculty Development Programme and is valid for payment during the financial year 2017-18.
4. Funds covered by this grant shall be kept separately and would not be mixed up with other funds.
5. The Council or its nominee shall have the right to check/verify the accounts to satisfy that the funds have been utilized for the purpose for which they were sanctioned.
6. The Principal and the Coordinator of the institute are requested to verify the correctness of the under mentioned bank account/ RTGS details submitted by them along with the Proposal, in which the grant is being released. In case of any omission the same should be reported to AICTE immediately along with refund of entire grant: -

Institute PAN No.	Bank Name	Bank Branch Name	Bank Branch Address	Account Holder Name	Account Type	Account Number	IFSC Code
AAATN3061E	INDIAN BANK	NHCE EXTENSION	RING ROAD, NEAR MARATHAHALLI, KADUBISANAHALLI, BANGALORE	NEW HORIZON COLLEGE OF ENGINEERING	Saving Account	484700078	IDIB000N112

Contd.....2

::2::

7. The University/College/Institute shall maintain proper accounts of the expenditure out of the grants, which shall be utilized only on approved items of expenditure.
8. Interest on the sanctioned grant will be reported back to AICTE and may be adjusted against the subsequent installment.
9. 90% of sanctioned amount to Govt. Institutions and 50% of sanctioned amount as advance to Self-Financing Institutions shall be released on the basis of Approval Letter for 2016-17. Those Institutes/Colleges, who have already conducted the event after submitting the application in the financial year, shall not be paid any advance payment. They may send the expenditure account and other relevant documents within one month of receipt of this letter for final settlement and reimbursement.
10. The grant is intended to cover items of expenditure connected with the Faculty Development Programme such as Boarding & Lodging to the participants, TA to outstation participants, Honorarium to Course Coordinator, Reading material to participants, Honorarium to Resource Persons, TA/DA to resource persons including two outstations resource persons & Working Expenses (reprographic services, postage, transport, daily wages, tea/coffee etc.
11. The Council shall sanction a maximum grant of Rupees Seven Lakh only to conduct one Programme. The expenditure under the Heads 'Honorarium to Course Coordinator' and 'Honorarium to Resource Persons' shall not exceed 1% & 20% respectively of the total sanctioned grant for the Programme. However, overall expenditure shall not exceed the funds sanctioned for the Programme.
Type of trainings under FDP shall be as under:
 - I. Pedagogical Training
 - II. Subject related Training
 - III. Training related to Moral Values, Ethics, Behavioural Sciences & Attitude etc.
 - IV. Training on Leadership & Faculty Development under U.K. India Education Research initiative (UKIERI)
12. The balance amount will be reimbursed to the institutions only on submission of duly audited utilization certificate and other relevant documents.
13. The reimbursement of the balance entitled amount of the grant-in-aid shall be released only on receipt of the following documents: -
 - (i) Feedback form in the prescribed proforma.
 - (ii) Original Statement of actual expenditure & Utilization Certificate in the prescribed proforma duly signed by the Head of the institution and countersigned by Registrar/Finance Officer/Govt. Auditor. In case of self-financing/private institutions, Statement of actual Expenditure along with paid vouchers & Utilization Certificate are required to be audited & signed and sealed by a Chartered Accountant endorsing the membership number and complete postal address.
Photocopies of formats are enclosed.
 - (iii) Copy of the proceedings and completion report.
 - (iv) **If programme is not conducted in the period of six months of the issuance of this Offer Letter, the released amount, along with interest accrued thereon, has to be returned to AICTE.**
14. The documents mentioned above must be sent within one month of the completion of the Faculty Development Programme held with approved financial assistance. On receipt of these documents, the total amount of financial assistance admissible as per the norms shall be worked out and grant-in-aid shall be released in favour of the beneficiary institution.
15. Any unavoidable circumstantial change in the Programme with respect to name of Project Coordinator, Venue and date for organizing FDP would mandatorily require prior approval of the Council. All such

requests should be addressed to AICTE, in advance, recording the specific reasons for proposed changes, failing which the offer for the grant already issued would be treated as automatically withdrawn and the financial assistance released in favour of the beneficiary institution shall be refunded immediately to the Council. Kindly mention the File No. 6-87/RIFD/FDP/Policy-1/2016-17 in your future correspondence.

16. The FDP will be organized for 2 weeks with minimum 50 participants and the institute should strictly observe all the terms and conditions contained in the scheme details under AICTE AQIS 2016-17.
17. The grant is subject to the adjustment on the basis of Utilization Certificate in the prescribed proforma submitted by the University/College/Institution. Further, the accounts of the institute will be open for test check by the Council or Controller & Auditor General of India or any other officer designated by them.
18. The University/College/Institute shall maintain proper accounts of the expenditure out of the grants which shall be utilized only on the approved items of expenditure.
19. This Sanction Order may be treated as Offer Letter for all purposes.

Yours sincerely,

(Dileep N Malkhede)
Advisor-I (RIFD) 717117

Copy forwarded for information and necessary action to: -

1. **Dr. MOHAN S,**
Department of COMPUTER SCIENCE AND ENGINEERING
NEW HORIZON COLLEGE OF ENGINEERING (E&T)
RING ROAD, NEAR MARATHALLI, BELLANDUR POST,
KADUBHISANAHALLI
BANGALORE URBAN
Pin No. 560103
Karnataka
2. **THE REGISTRAR / DIRECTOR / PRINCIPAL**
NEW HORIZON COLLEGE OF ENGINEERING (E&T)
RING ROAD, NEAR MARATHALLI, BELLANDUR POST,
KADUBHISANAHALLI
BANGALORE URBAN
Pin no. 560103
Karnataka
3. Guard File

ALL INDIA COUNCIL FOR TECHNICAL EDUCATION

Nelson Mandela Marg, Vasant Kunj,
New Delhi-110067,

Ref. No.: File No. 8-64/RIFD/RPS/POLICY-1/2016-17

Date: 4 August 2017

The Drawing and Disbursing Officer
All India Council for Technical Education
Nelson Mandela Marg,
Vasant Kunj, New Delhi-110067,

Sub: Release of a sum of Rs.1326853/- being the 1st installment of the total grant of Rs.1347059/- for conduct of Project under Research Promotion Scheme (RPS) during the financial year 2017-18.

Sir,

With reference to the Proposal submitted by the institute, this is to convey the sanction of the Council for payment of **Rs.1326853/- (Rupees Thirteen Lakh Twenty Six Thousand Eight Hundred Fifty Three)** as 1st installment out of a total approved grant-in-aid of **Rs.1347059/-** for conduct of a Project under the Research Promotion Scheme (RPS), as per details given below:-

- | | | |
|---|---|--|
| I. Name of the Beneficiary Institution (University / College / Institution) | : | NEW HORIZON COLLEGE OF ENGINEERING (E&T) RING ROAD, NEAR MARATHALLI BELLANDUR POST, KADUBHISANAHALLI, BANGALORE, KARNATAKA-560103 |
| II. Principal Investigator's Name & Dept./Course | : | Dr. GANESH PRASAD M. S MECHANICAL ENGINEERING |
| III. Grant-in-aid Sanctioned | : | Rs.1347059/- (Rs. 1145000/- for non-recurring and Rs.202059/- for recurring expenditure) |
| IV. Amount to be Released during the year 2017-18 | : | Rs.1326853/- (Full amount of non recurring & 90 % of recurring sanctioned) |
| V. Duration | : | 3 Years |
| VI. Title of the Project | : | MULTI-PURPOSE COMPACT SOLAR FRUIT DRYER |

1. The sanctioned grant-in-aid is debitable to the major "601.1(a) (RPS)" Gen. and is valid for Payment during the financial year 2017-18.
2. The grant-in-aid of the grant shall be drawn by the Drawing and Disbursing Officer (DDO), All India Council for Technical Education, New Delhi on the Grants-in-aid bill and shall be disbursed to and credited to the account of **NEW HORIZON COLLEGE OF ENGINEERING (E&T), RING ROAD, NEAR MARATHALLI BELLANDUR POST, KADUBHISANAHALLI, BANGALORE, KARNATAKA-560103** through RTGS.
3. The date of release of the grant by AICTE shall be taken as the date of commencement of the project. The **Principal/Director/Registrar** shall intimate about the receipt of the grant to AICTE. Any Expenditure, incurred prior to issuance of this Sanction Order, is not allowed to be adjusted in the grant and if the University/Institution do not take the project work within 6 months of the receipt of the grant, approval shall ipso facto lapse.

Contd...2/-

:: 2 ::

4. Each project sanctioned by AICTE is assigned a specific Ref. No. which is on pre-page. All correspondence addressed to AICTE regarding the project must quote this number along with year of sanction of the Project, otherwise the correspondence may not be entertained.
5. The accounts of the grantee will be open for test check by the Council or Comptroller & Auditor General of India or by any officer designated by them.
6. The Principal and PI of the institute are requested to verify the correctness of the under mentioned bank account/RTGS details submitted by them along with the Proposal, in which the grant is being released. In case of any omission, the same should be reported to AICTE immediately along with refund of entire grant:-

Institute PAN No.	Bank Name	Bank Branch	Bank Branch Add.	Account Holder Name	Account Type	Account Number	IFSC Code
AAATN3061E	INDIAN BANK	NHCE EXTENSION	RING ROAD, NEAR MARATHAHALLI, KADUBISANAHALLI, BANGALORE	NEW HORIZON COLLEGE OF ENGINEERING	Saving Account	484700078	IDIB000N112

7. The institute/University shall not charge any overheads on this Project and will provide all the administrative support for completion of the Project.
8. The grantee shall utilize grants on only approved items, as per list of equipment attached. However if the grantee wishes to recast the Project, approval of Council must be obtained for the revised item of expenditure and they will maintain proper accounts of the expenditure as per the norms/procedures of AICTE/Government of India.
9. The assets acquired wholly or substantially out of All India Council for Technical Education's grant shall not be disposed or encumbered or utilized for the purpose other than those for which the Grant was given without proper sanction of the All India Council for Technical Education.
10. The grantee shall maintain an audited record of assets acquired wholly or substantially out of the grant-in-aid and a register for assets shall be maintained by the Institute in the prescribed form i.e. GFR-19.
11. Interest accrued on the sanctioned grant-in-aid will be reported back to AICTE and may be adjusted against the subsequent installment.
12. The following documents, in the prescribed format, are required to be submitted to AICTE by the PI/Institute, as per time schedule given below:-

Documents to be submitted within one month of completion of each financial year.

- The Annual Progress Report, indicating therein the number of patents, publications or any other achievement.
- Utilization Certificate duly audited.
- Audited record of assets acquired wholly or substantially out of the grant-in-aid and a register for assets in the prescribed form i.e. GFR-19.
- Bills/vouchers related to Non-recurring expenditure duly signed & stamped by the PI & Head of the institution.
- Stock entry register duly verified by the Store-in-charge and PI & counter signed by Head of institution.

:: 3 ::

Documents to be submitted within two month of completion of the Project.

- The consolidated Utilization Certificate (UC), duly audited.
- Duly audited statement of expenditure, to the effect that the grant has been utilized for the purpose for which it has been sanctioned. It should contain the head-wise break up of expenditure made from the grant-in-aid provided by the Council.
- Project Completion Report duly signed & stamped by the PI & Head of the institution.

Any deviation from the above said time schedule will cause serious action against the institute.

13. **The grantee shall follow the terms and conditions of Research Promotion Scheme (RPS) as laid down by the Council from time to time.**
14. The Grantee shall fully implement to the Official Language policy of Union Government and comply with the official language Act, 1963 and official language (use of official purposes of the Union Rules, 1976 etc.)
15. The funds to the extent are available under the Scheme.
16. The sanction issues in exercise of the powers delegated to the Council. It is also certified that grant-in-aid is being released in conformity with the rules and principles of the Scheme.
17. The budget allowed cannot be utilized for hiring temporary or permanent staff for the Project.
18. **It should be ensured that no RPS project in favour of the same P.I. has been sanctioned during the last 03 years before utilizing this amount and the matter be brought to the notice of this Council immediately.**
19. The institute should strictly observe all the terms & conditions contain in the Scheme details under AICTE AQIS 2016-17.

Yours sincerely,

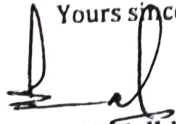
(Dileep N. Malkhede)
Advisor (RIFD)

Note: The prescribed formats and Terms & Conditions are available in the application brochure.

Copy forwarded for information and necessary action to:

17 AUG 2017

1. Principal/Director/Registrar,
NEW HORIZON COLLEGE OF ENGINEERING (E&T),
RING ROAD, NEAR MARATHALLI BELLANDUR POST,
KADUBHISANAHALLI, BANGALORE, KARNATAKA-560103

2. ✓ Dr. GANESH PRASAD M. S,
DEPT. OF MECHANICAL ENGINEERING,
NEW HORIZON COLLEGE OF ENGINEERING (E&T),
RING ROAD, NEAR MARATHALLI BELLANDUR POST,
KADUBHISANAHALLI, BANGALORE, KARNATAKA-560103

3. OFFICE OF DIRECTOR GENERAL OF AUDIT
GENERAL REVENUES, AGCR BUILDING
I.P. STATE, NEW DELHI-110002.

4. Guard File

ALL INDIA COUNCIL FOR TECHNICAL EDUCATION
Nelson Mandela Marg, Vasant Kunj
New Delhi-110067

Ref. No.: 8-64/RIFD/RPS/POLICY-1/2016-17

Name of the
Principal
Investigator &
Dept./Course

: Dr. GANESH PRASAD M. S
MECHANICAL ENGINEERING

Name of the
Institution

: NEW HORIZON COLLEGE OF ENGINEERING
(E&T)
RING ROAD, NEAR MARATHALLI BELLANDUR
POST, KADUBHISANAHALLI, BANGALORE,
KARNATAKA-560103

Title of the Project

: MULTI-PURPOSE COMPACT SOLAR FRUIT
DRYER

Approved Items of Expenditure (Non-Recurring)

Sl. No.	Approved Items (As per proposai) *	No. of Units	Total Amount Recommended
1	Flexible Bendable Solar Panel	10	1145000/-
2	Refrigeration Unit	01	
3	Tubular Battery	10	
4	Solar Conversion Unit	10	
5	Solar Charge Controller	10	
6	Centrifugal Air Blower	02	
7	Suction fans	05	
8	Temperature sensors	20	
9	Dehydrator	03	
10	Moisture tester	05	
11	Solar Panels	10	

(Dileep N Malkhede)
Advisor (RIFD)

08 SEP 2017

ALL INDIA COUNCIL FOR TECHNICAL EDUCATION
Nelson Mandela Marg, Vasant Kunj, New Delhi-110067

2017

Ref No. 9-117/RIFD/MODROB/Policy-1/2016-17

The Drawing and Disbursing Officer
Local

Subject: Release of Grant-in-Aid under Modernization and Removal of Obsolescence Scheme (MODROBS) for the year 2017-18 payable during the current financial year 2017-18.

Sir,

I am directed to convey the sanction of the Council for payment of Rs. 1070529.6000000001/- (Rupees Ten Lakh Seventy Thousand Five Hundred TwentyNine Paise Sixty Only) for the year 2017-18 under the Modernization and Removal of Obsolescence Scheme (MODROBS) to New Horizon College Of Engineering (E&T), Ring Road, Near Marathalli, Bellandur Post, Kadubhisanahalli-560103Karnataka for incurring the expenditure for implementing the Scheme as per details given below:

- | | |
|---|---|
| 1. Name of the Beneficiary Institution | : New Horizon College of Engineering (E&T), Ring Road, Near Marathalli, Bellandur Post, Kadubhisanahalli-560103 Karnataka |
| 2. Chief Coordinator's Name & Deptt. | : Dr. Elumalai R,
Deptt. of Electrical And Electronics Engineering |
| 3. Title of the Project | : Modernization of high voltage engineering lab |
| 4. Grant-in-aid Sanctioned
(80% in advance and 20% as reimbursement on submission of UC and other related documents) | : Rs.1338162/- (Rs.1102016/- for non-recurring and Rs.236146/- for recurring expenditure) |
| 5. Amount to be released | : Rs. 1070529/- |
| 6. Approved Duration (in years) | : 2 Year |

- The sanctioned grant-in-aid is debitible to the major Head 601.4.a MODROBS grant and is valid for payment during the financial year 2017-18.
- The grant-in-aid of the grant shall be drawn by the Drawing and Disbursing Officer (DDO), All India Council for Technical Education, New Delhi on the Grants-in-aid bill and shall be disbursed to and credited to the account of The Principal / Director / Registrar New Horizon College Of Engineering (E&T), Ring Road, Near Marathalli, Bellandur Post, Kadubhisanahalli-560103Karnataka.
- The institute is requested to verify the correctness of the under mention bank account/ RTGD submitted by them along with the proposals, in which the grant is being released. In case of any omission the same should be reported to AICTE immediately along with refund of entire grant.

Bank Name	Bank Branch and address	Account Holder's Name	Account Number	Type of Account	IFSC Code	Type of Institution	Institution's PAN No.
INDIAN BANK	NHCE EXTENSION, RING ROAD, NEAR MARATHAHALLI, KADUBISANAHALLI, BANGALORE	NEW HORIZON COLLEGE OF ENGINEERING	484700078	Saving Account	IDIB000N112	Unaided Private	AAATN3061E

- The date of release of the grant by AICTE shall be taken as the date of commencement of the project. The Principal / Director / Registrar shall intimate about the receipt of the grant to AICTE. Any Expenditure incurred prior to the issuance of the approval letter will not be allowed to be adjusted in the grant and if the Institution / University do not take the project work within one month of the receipt of the grant, the approval shall ipso facto lapse.
- Each project sanctioned by AICTE is assigned a specific Ref. No. given on the pre-page. All correspondences related to the project must contain this number along with year of sanction of the project; failing which correspondence will not be entertained.
- The accounts of the grantee which are liable to be audited by the Council or Comptroller and Audited General of India or by any Officer designated for the purpose.
- The Institute/University shall not charge any overheads on this project and will provide all the administrative support for completion of the project.

To: ~~The Head Office~~
The Registrar (my Coord...2)
The Dean R&D
21/11/17

8. The grantee shall utilize grants on only approved items of expenditure (list enclosed). However in case the grantee wishes to recast the project, approval of the Council must be obtained for the revised item of expenditure and they will maintain proper accounts of the expenditure as per the norms/procedures of AICTE/Government of India.
9. The assets acquired wholly or substantially out of All India Council for Technical Education's grant shall not be disposed or encumbered or utilize for the purpose other than those for which the Grant was given without proper sanction of the All India Council for Technical Education and should at any time the institution cease to function, such assets shall revert to the All India Council for Technical Education.
10. The grantee shall maintain an audited record of assets acquired wholly or substantially out of the grant-in-aid and a register or assets shall be maintained by the Institute in the prescribed form i.e. GFR-19.
11. The amount of interest accrued on the grant should be treated as part of the grant to be utilized for that particular project. However, the interest amount accrued along with grant disbursed should not exceed the total grant sanctioned for the project. The Institute receiving the grant should reflect the same in the audited statement of accounts/ utilization certificate and may either refund the interest amount to AICTE or AICTE should adjust the same in the next installment of grant before releasing.
12. Since the duration of the project is for two years, the request for reimbursement of 20% of remaining amount shall be made with UC and other related documents in such a way that the entire project is completed in the prescribed period of two years.
13. The Annual Progress Report in the prescribed format along with Statement of Expenditure and Audited Utilization Certificate shall be submitted to AICTE not later than one month after completion.
14. Project Completion Report (PCR) in the prescribed format along with the Audited Statement of Expenditure indicating expenditure incurred in the total duration of the project in the prescribed format, utilization in the format and GFR-19 shall be submitted to the Council.
15. The Utilization Certificate (UC) supported by Audited Statement of Expenditure to the effect that the grant has been utilized for the purpose for which it has been sanctioned shall be furnished to the All India Council for Technical Education immediately after completion of the project. It should contain the head-wise break up of expenditure made from the grant-in-aid provided by the Council.
16. The grantee shall follow the terms and conditions of Modernization and Removal of Obsolescence (MODROBS) as laid down in the scheme details under AICTE AOIS 2016-17.
17. The Grantee shall fully implement the official language policy of Union Government and comply with the official language Act, 1963 and official language (use of official purposes of the Union Rules, 1976 etc.)
18. The University / Institute receiving grant under MODROB is expected to put up a plaque at the main entrance of the Lab/Department, which has been modernized using the grant. All the equipment procured through the project should be super scribed with AICTE project file number.
19. The funds to the extent are available under the scheme.
20. The sanction issues in exercise of the powers delegated to the Council. It is also certified that grant-in-aid is being released in conformity with the Rules and Regulation of the scheme.

Yours sincerely,

(Dileep N. Malkhed e)
Advisor (RIFD)

09 SEP 2017

Copy forwarded for information and necessary action to:

1. The Principal / Director / Registrar,
New Horizon College of Engineering (E&T),
Ring Road, Near Marathalli, Bellandur Post,
Kadubhisanaahalli-560103Karnataka
2. Dr. Elumalai R.,
Deptt of Electrical And Electronics Engineering
Ring Road, Near Marathalli, Bellandur Post,
Kadubhisanaahalli-560103Karnataka
3. Office of Director General of Audit,
General Revenues, AGCR Building, I.P. Estate,
New Delhi-110 002.
4. ~~Chief Clerk~~



Karnataka Science and Technology Promotion Society (KSTePS)

Dept. of Information Technology, Bio Technology and Science & Technology, Government of Karnataka

"Vijnana Bhavana", 3rd Floor, #24/2, 21st Main Road, Banashankari 2nd Stage, Bangalore

Ph/fax : 080-26711166, E-mail : ksteps.dst@gmail.com

*Dr. H. Honne Gowda
Special Director (Technical),
Dept. of IT, BT and S&T/
Managing Director, KSTePS*

No. KSTePS/VGST-SMYSR/2016-'17 /280/2

Date: 27.11.2017

Dear Sir,

Sub: Intimation of selection of the project under the VGST scheme of SMYSR-reg.

Greetings from the Dept. of Information Technology, Biotechnology and Science & Technology!!

We are pleased to inform you that the project titled "**Green energy-hybrid renewable power generation (solar-wind) for irrigation**" submitted under the VGST scheme of SMYSR for the financial year 2016-'17 has been approved by the Government based on the recommendations of Vision Group on Science and Technology under the Chairmanship of Prof. CNR Rao, Honorary President, INCASR.

You are requested to take an immediate action to initiate the project at the earliest and to be completed within a year after receiving the cheque of 1st installment from our office. The total grant allocated for the project is Rs. 5.00 lakh.

The grant will be paid to the Head of the Institution, under whose supervision the Principal Investigator shall be responsible for completion of the stated objectives of the project. The Principal Investigator through the Institution Head shall have to submit the progress report in soft copy (word & pdf) once in 3 months without any fail. The grants shall be used only for the purposes described in the grant application by following due procedures of KTPP Act. Any deviation from the scheduled plan must have a prior approval from the VGST. A sample copy of the Utilization Certificate is enclosed for information and necessary action in the future.

The funding agency has the right to terminate the project, if it is found to be not satisfactorily pursuing and fulfilling the stated project goals and objectives. Any

unspent balance must be returned back to the funding agency within 60 days following the conclusion of the project. Any publications or other dissemination arising from research supported by VGST grants should be acknowledged.

Dr. S. G. Sreekanteswara Swamy, Consultant, VGST will be the nodal officer for all future correspondences related to the project. His contact details are given below:

Vision Group on Science and Technology
Dept. of IT, BT and S&T, Karnataka Government Secretariat,
Room No. 702, 7th Floor, 4th Gate,
M.S. Building, Dr. Ambedkar Veedhi,
Bangalore – 560001.

Phone : 080-2203 2013
Email : visiongroup.st@gmail.com
Website : www.vgst.in

I want to personally thank you for being selected as one of the VGST program members and we wish you and the Principal Investigator a great success in the implementation of the project.

Thanking you

Yours sincerely,

(H. Honne Gowda)

To,
The Principal
New Horizon College of Engineering
Outer Ring Road, Near Marathalli, Bellandur Main Road,
Bengaluru, Karnataka 560103

CC:

✓ Dr. Mahesh K, Program Coordinator, Dept. of Electrical and Electronics Engineering,
New Horizon College of Engineering, Outer Ring Road, Near Marathalli, Bellandur
Main Road, Bengaluru, Karnataka 560103

Ref: CubeSat/ADSB/Indo-Israel JD/001

15 September 2016

To

The Principal (*Attention to Prof & HoD, Dept of Mech/CSE/ECE*)

New Horizon College of Engineering (NHCE)

Outer Ring Road, Kadubesnahalli,

BANGALORE, KARNATAKA

Dear Professor,

SUB: Sanction of Grant-in-Aid-Joint Development- Design and Development of CubeSat 2U; ADSB including Launch Cost; Indo-Israel Joint Development under UNISEC India (Timeline: 24 Months). Indo-Israel Joint Development- 24 Months (2017-18 & 2018-19)- Rs.26,00,000/- (Cash/Kind)- Partnering Funding Agencies: ITCA, UNISEC India, DRL, TSC P Ltd-Reg.

REF: Your Project Proposal in Response to Announcement of Opportunity-Our Interactions/On-line Meetings/MoU Signed with Your Institution on 05 April 2016

Under the powers vested with Programme Office for the Indo-Israel Joint Development Programme under UNISEC India as per the ITCA-TMIsat-UNISEC India-DRL-TSC Consortium which has signed MoU on 05 April 2016 and subsequent Announcement of Opportunity issued,

I am directed to convey the sanction of the following project for the respective years from 2017-18 & 2018-19:

Project Split-up	26,00,000/-
2017-18 (Project Split-up Among Departments)	
<i>Dept. Mech: Design and Development of Satellite Monolithic Structure, Machining, Orbital Mechanics-Calculation-Simulation</i>	4,00,000/-
<i>Dept. CSE: On Board Computer (OBC), Coding and Programming Responsibilities</i>	5,00,000/-
2018-19 (Project Split-up Among Departments)	
<i>Dept. Mech: Design and Development of Satellite Monolithic Structure, Machining, Orbital Mechanics-Calculation-Simulation</i>	5,00,000/-
<i>Dept. CSE: On Board Computer (OBC), Coding and Programming Responsibilities</i>	9,00,000/-
<i>Dept. ECE: 18 Months: CDR, HWDR, EPS, Telemetry, Onboard Systems and Subsystems, Antenna Deployment, Integration Services, Testing and Qualifications for Launch etc</i>	3,00,000/-

Terms and Conditions of Sanction of Grant-in-Aid

1. Funds for second installment will be released on satisfactory progress and submission of six month progress report by PI to the Programme Office and based on recommendation with due approval of competent authority.
2. Statement of accounts and utilization certificate duly certified by the executive financial authority of the Institution is also required to be submitted along with the annual report. Excess expenditure, beyond the sanctioned amount, shall be responsibility of grantee institution.

3. The duration of the project is TWENTY FOUR MONTHS (2 Years) with review after six months! The date of receipt of the grant would be reckoned as the commencement date of the project which has to be intimated to the Programme Office without any ambiguity.
4. A separate account for the grant would be maintained by New Horizon College of Engineering (NHCE) and any interest earned thereon, if any, would accrue to CubeSat 2U Programme.
5. Unspent balance, on completion of the project should be sent by the grantee institution through a RTGS/Cheque/Draft/in Kind in the name of ITCA/UNISEC India/TMISat/TSC Technologies P Ltd, Bangalore for doing the needful.
6. A list of inventory of equipment purchased out of the Programme grant shall be intimated year-wise, along with its cost and source of procurement to the Programme Office.
7. On completion of the project, the grantee institution would forward the consolidated list with request, if any, for the retention of any equipment for another project or in-house R&D, with due recommendations of their executive authority and the concerned panel.
8. In case of any joint publications of Technical Research Papers related to this project as a part/outcome of the research works shall have the mentioning/acknowledgement of consortium which has granted the matching grant for the project appropriately.
9. A Closure Report alongwith copies of technical report may be submitted within sixty days of completion of project alongwith Statement-2 (Statement of Expenditure) and Statement -3 (Utilization Certificate) as per the Annexure III of Grants-in-aids rules duly audited from the Audit Authority of Institution signed in ink in duplicate.
10. UNISEC India/TMISat/ITCA/TSC Technologies P Ltd, Bangalore will make disbursement of money/equivalent in kind as sanctioned.

With best regards,

Yours sincerely,



*Secretary General, Indian Technology Congress Association and UNISEC-India
Convener, 75 Students' Satellite Consortium: Mission 2022*

Copy to

- a) Programme Director, Indo-Israel Joint Development Programme Office, Bangalore
- b) President, Indian Technology Congress Association
- c) Head, TMISat, Isarel
- d) Convener, 75 Students' Satellites Consortium: Mission 2022
- e) Professor and HoDs, Mech/CSE/ECE, NHCE, Bangalore

Indian Technology Congress Association

#3, 4th Floor, First Main, BDA Layout, Kodihalli, HAL 2nd Stage, Bengaluru - 560 008.

<https://www.itca.org.in/>



UNISEC Global, HQ at Japan

<http://www.unisec-global.org/localchapters.html>

Under Association of Indian Local Chapters

University Space Engineering Consortium (UNISEC)-INDIA

Secretariat, 4th Floor, #3, First Main, BDA Layout, Kodihalli, HAL 2nd Stage, Bengaluru – 560008, Karnataka, India. Ph: 080 6559 2501; 080 4850 8380; Website: www.unisec-india.in

Ref: SiCS-B/Sat Bus/JD-Indo-Israel/001

23 September 2016

To

The Principal (*Attention to Prof & HoD, Dept of Mech/CSE/ECE*)

New Horizon College of Engineering (NHCE)

Outer Ring Road, Kadubesnahalli,

BANGALORE, KARNATAKA

**Development of “Single Card Satellite-Bus (SiCS-B)”: 10 cm x 10 cm
(Timeline: 30 Months). Indo-Israel Joint Development
Partnering Funding Agencies: ITCA-TMISat, UNISEC India, DRL, TSC P Ltd**

Dear Professor,

**SUB: Sanction of Grant-in-Aid-Joint Development- Development of “Single Card Satellite-Bus (SiCS-B)”:
10 cm x 10 cm (Timeline: 30 Months). Indo-Israel Joint Development- 30 Months (2016-17 to
2017-18)-Rs.15,00,000/-Reg.**

**REF: Your Project Proposal in Response to Announcement of Opportunity-Our Interactions/On-line
Meetings/MoU Signed with Your Institution on 05 April 2016**

Under the powers vested with Programme Office for the Indo-Israel Joint Development Programme as per the ITCA-TMISat-UNISEC India-DRL-TSC Consortium which has signed MoU on 05 April 2016 and subsequent Announcement of Opportunity issued,

I am directed to convey the sanction of the following project for the respective years from 2016-17 to 2017-18:

2016-17 (Project Split-up Among Departments)

Dept. Mech: Design and Development of Satellite Monolithic Structure, Machining- Prototype: **Rs. 1,50,000/-**

Dept. CSE: On Board Computer (OBC), Coding and Programming Responsibilities: **Rs. 5,00,000/-**

2017-18 (Project Split-up Among Departments)

Dept. Mech: Design and Development of Satellite Monolithic Structure, Machining, Orbital Mechanics- Calculation-Simulation- Phase 1: **Rs. 3,00,000/-**

Dept. CSE: On Board Computer (OBC), Coding and Programming Responsibilities: **Rs. 5,00,000/-**

Overall Contingencies, Travel, Overhead Charges and Miscellaneous Expenditures: **Rs. 50,000/-**

Terms and Conditions of Sanction of Grant-in-Aid

1. Funds for second installment will be released on satisfactory progress and submission of six month progress report by PI to the Programme Office and based on recommendation with due approval of competent authority.

2. Statement of accounts and utilization certificate duly certified by the executive financial authority of the Institution is also required to be submitted along with the annual report. Excess expenditure, beyond the sanctioned amount, shall be responsibility of grantee institution.
3. The duration of the project is THIRTY MONTHS (2.5 Years) with review after six months! The date of receipt of the grant would be reckoned as the commencement date of the project which has to be intimated to the Programme Office without any ambiguity.
4. A separate account for the grant would be maintained by New Horizon College of Engineering and any interest earned thereon, if any, would accrue to SiCS-B Programme.
5. Unspent balance, on completion of the project should be sent by the grantee institution through a RTGS/Cheque/Draft/in Kind in the name of UNISEC India/TMISat/ITCA/TSC Technologies P Ltd, Bangalore for doing the needful.
6. A list of inventory of equipment purchased out of the Programme grant shall be intimated year-wise, along with its cost and source of procurement to the Programme Office.
7. On completion of the project, the grantee institution would forward the consolidated list with request, if any, for the retention of any equipment for another project or in-house R&D, with due recommendations of their executive authority and the concerned panel.
8. In case of any joint publications of Technical Research Papers related to this project as a part/outcome of the research works shall have the mentioning/acknowledgement of consortium which has granted the matching grant for the project appropriately.
9. A Closure Report alongwith copies of technical report may be submitted within sixty days of completion of project alongwith Statement-2 (Statement of Expenditure) and Statement -3 (Utilization Certificate) as per the Annexure III of Grants-in-aids rules duly audited from the Audit Authority of Institution signed in ink in duplicate.
10. UNISEC India/TMISat/ITCA/TSC Technologies P Ltd, Bangalore will make disbursement of money/equivalent in kind as sanctioned.

With Warm Regards,

Truly Yours,



(Dr. L. V. MURALIKRISHNA REDDY)

President, UNISEC India

President, 75 Students' Satellites Consortium: Mission 2022

Copy to

- a) Programme Director, Indo-Israel Joint Development Programme Office, Bangalore
- b) President, Indian Technology Congress Association
- c) Head, TMISat, Isarel
- d) Convener, 75 Students' Satellites Consortium: Mission 2022
- e) Professor and HoDs, Mech/CSE/ECE, NHCE, Bangalore



Dr. L.V. Muralikrishna Reddy
President

Foundation for Advanced Research & Education

(Registered Society under K.S.R. Act, 1960, Reg. No. BLU-S 630-2005-06, 14 September 2005)

#3, 4th Floor, First Main, BDA Layout, Kodihalli, HAL 2nd Stage, Bangalore - 560 008.
Phone: 080 -65592501 TeleFax: 48508380
E-mail: fareinfo@gmail.com Web: fareindia.org

Ref.: FARE/2017-18/47A

15 June 2017

To

The Principal,

New Horizon College of Engineering,

Outer Ring Road,

Bangalore-560103

M: 99019 16000

SUB: Collaborative Event with ITCA-Open Innovation Hackathon- Grant of Sponsorship- INR 1,80,000/-2017-18-Reg.

REF: Our Telephonic Conversation with Dr. K. Gopalakrishnan, Dean (R&D)-NHCE

Dear Sir,

With reference to the above subject, we have agreed to grant INR. 1,80,000/- (Indian Rupees One Lakh Eighty Thousand only) as our sponsorship towards the publication of proceedings and coordinating the « Open Innovation Hackathon » during Novemebr 2017 at New Horizon College of Engineering, Bnaglore.

Top THREE successful Teams will be considered for « development of PoC to protype » and furture funding options also can be explored. Kindly involve HoDs and Professors of CSE, ISE and MCA Departments for identifying suitable domain experts to constitute the Jury for the Hackathon in consultation with Mr. Ganesan Narayanasamy, IBM OpenPOWER Foundation.

With Warm Regards,

Yours Sincerely,

(Dr. L.V. MURALIKRISHNA REDDY)

Cc to :

1. *Dr. S. Mohankumar, NHCE and Organising Secretary, Open Innovation Hackathon 2017*
2. *Secretary General, ITCA*
3. *Mr. Ganesan Narayanasamy, IBM*
4. *File*

Open INNOVATION Hackathon-2017: In Association with ITCA



**Indian
Technology
Congress
Association**

Re: Project ID: DR2019002: INVESTIGATIONS ALONG WITH DESIGN, DEVELOPMENT AND TESTING ON USE OF CURRENT SOURCE INVERTER (CSI)(1KW, 440 V) FOR GRID CONNECTED SOLAR PV FOR RESIDENTIAL/APARTMENT APPLICATIONS

6 messages

RESEARCH IEI <research@ieindia.org>
To: Nisha Shaji <nishashaji2007@gmail.com>

Mon, Jul 2, 2018 at 4:55 PM

R.6/2/DR/2018-19/RDDR2018002 [Permanent ID: DR2019002]

Dear Sir/Madam,

The sanctioned amount of Rs.35,000/- under IEI R&D Grant-in-Aid scheme against the subject project has been transferred through NEFT on 22.06.2018 as per Payee Details provided by you. The transaction no. is NEFT/SK/AXSK181730032566.

Please check with the appropriate authority of your institute and confirm receipt of the amount via mail.

With best regards,

IEI R&D Cell
Technical Department
The Institution of Engineers (India)
8 Gokhale Road, Kolkata-700020
West Bengal, India.

Website: www.ieindia.org

On Wed, Jan 10, 2018 at 9:55 PM, Nisha Shaji <nishashaji2007@gmail.com> wrote:

Respected Sir

With reference to the mail received on 5th January 2018 (Tech/D.18) about the Project Title: "INVESTIGATIONS ALONG WITH DESIGN, DEVELOPMENT AND TESTING ON USE OF CURRENT SOURCE INVERTER (CSI)(1KW, 440 V) FOR GRID CONNECTED SOLAR PV FOR RESIDENTIAL/APARTMENT APPLICATIONS", send for IEI R&D Grant, I hereby resubmit the proposal with the following modification/ adequate documents:

1. Cancelled Cheque with Account payee detail is enclosed
2. Guides name is removed from the student section
3. Students' selection letter and USN document are enclosed
4. NAAC and NBA Accreditation Certificate, Autonomous Status notification document are enclosed
5. Payment proof for IEI Member of student is enclosed
6. Under details of Finance requirement, Per unit cost of S.No.1 and cos of BOS in S.No:2 is incorporated

Regards and Thanks
Dr.Nisha K C R
Associate Professor
Department of Electronics and Communication Engineering
New Horizon College of Engineering



STUDENT PROJECT PROGRAM: 2016 - 17

BIOFUEL PROJECTS

**COMPENDIUM OF
40TH SERIES SPP: BIOFUEL PROJECTS**

**KARNATAKA STATE COUNCIL FOR SCIENCE
AND TECHNOLOGY**

Indian Institute of Science Campus, Bengaluru - 560 012

Supported by

KARNATAKA STATE BIOENERGY DEVELOPMENT BOARD

Department of Rural Development and Panchayath Raj, Government of Karnataka

24) NEW HORIZON COLLEGE OF ENGINEERING, BENGALURU

Sl. No.	Proj. Ref. No.	TITLE OF THE PROJECT	BRANCH	NAME OF THE GUIDE/S	STUDENT1 & TEAM LEADER
35.	40S_B_BE_027	SCALE-UP STUDIES OF MICROALGAE CHLOELLA ROTUNDA FOR BIOLIPIDS (BIODIESEL) AS THIRD GENERATION BIOFUEL ALONG WITH VALUE-ADDED PRODUCTS USING WASTE-FREE TECHNOLOGY	BIOTECHNOLOGY	DR. R.S. UPENDRA & DR. PRATIMA KHANDELWAL	MS. SHALINI R.
36.	40S_B_BE_047	PEERFORMANCE AND EMISSION CHARACTERISTICS STUDY OF TYRE PYROLYSIS OIL DIESEL BLEND ON A SINGLE CYLINDER DIESEL ENGINE	AUTOMOBILE ENGINEERING	PROF. MOHAN KUMAR G.R.	MR. PAWAN A.R.

25) P.E.S. UNIVERSITY, BENGALURU

Sl. No.	Proj. Ref. No.	TITLE OF THE PROJECT	BRANCH	NAME OF THE GUIDE/S	STUDENT1 & TEAM LEADER
37.	40S_B_BE_080	SELF SUSTAINABLE BIO ENERGY MODEL SYNTHESIZED FROM KITCHEN WASTE	MECHANICAL ENGINEERING	DR. V. KRISHNAMURTHY, MR. AJAY NAYAR & MS. KAVITHA S.H.	MR. SHASHANK S. IYENGAR

26) R.R. INSTITUTE OF TECHNOLOGY, BENGALURU

Sl. No.	Proj. Ref. No.	TITLE OF THE PROJECT	BRANCH	NAME OF THE GUIDE/S	STUDENT1 & TEAM LEADER
38.	40S_B_BE_019	DEVELOPMENT OF UNIVERSAL TUBULAR MICRO ALGAE PHOTO-BIOREACTOR TO MEET HIGH YIELD	MECHANICAL ENGINEERING	MR. PAVAN KUMAR REDDY	MR. SUBRAMANYA UDUPA A

27) RAJARAJESWARI COLLEGE OF ENGINEERING, BENGALURU

Sl. No.	Proj. Ref. No.	TITLE OF THE PROJECT	BRANCH	NAME OF THE GUIDE/S	STUDENT1 & TEAM LEADER
39.	40S_B_BE_054	EXPERIMENTAL INVESTIGATION OF A SINGLE CYLINDER FOUR STROKE DIESEL ENGINE USING VEGETABLES OIL OF DIFFERENT PROPORTIONS WITH DIESEL	MECHANICAL ENGINEERING	PROF. N. SREENIVASALU REDDY & DR. PRUTHVIRAJ R.D.	MR. AKASH S.J.

28) REVA INSTIUTTE OF TECHNOLOGY AND MANAGEMENT, BENGALURU

40.	40S_B_BE_040	STUDY ON THE CORROSION BEHAVIOUR OF MILKSCUM BIODIESEL ON THE PISTON AND CYLINDER MATERIAL OF DIESEL ENGINE	MECHANICAL ENGINEERING	MR. VEERABHADRAPPA TELGANE	MR. ANOOP KUMAR SINGH
41.	40S_B_BE_041	CHARACTERIZATION OF MILK SCUM BIODIESEL AND A STUDY ON COMBUSTION CHARACTERISTICS OF CI ENGINE FUELLED WITH BLENDS OF MILK SCUM BIODIESEL	MECHANICAL ENGINEERING	MR. VEERABHADRAPPA TELGANE	MR. RAHUL KANAJE
42.	40S_B_BE_066	EFFECT OF EDDITIVES ON PERFORMANCE AND EMISSION CHARACTERISTICS OF SINGLE CYLINDER ENGINE USING VEGETABLE OIL BLENDED WITH BIODIESEL AS FUEL	MECHANICAL ENGINEERING	DR. SHARANAPPA GODIGANUR	MR. AMITH HIBARE

29) RURAL ENGINEERING COLLEGE, HULKOTI

43.	40S_B_BE_090	COMPARISON OF PERFORMANCE AND EMISSION TESTS USING BIODIESEL FROM SIMAROUBA AND CUSTARD APPLE SEEDS OIL IN CI ENGINE	MECHANICAL ENGINEERING	PROF. SIDDESH N. BEVINAHALLI	MR. ARVIND KUMAR M.
-----	--------------	--	------------------------	------------------------------	---------------------

KARNATAKA STATE COUNCIL FOR SCIENCE AND TECHNOLOGY

Indian Institute of Science Campus, Bengaluru - 560012

LIST OF B.E. PROJECTS SANCTIONED UNDER 40th SERIES OF STUDENT PROJECT PROGRAMME: 2016 - 2017

80) NEW HORIZON COLLEGE OF ENGINEERING, BENGALURU

SI No.	Project proposal Ref. No.	TITLE OF THE PROJECT	BRANCH	NAME OF THE GUIDE/S	STUDENT1 & TEAM LEADER	SANCTIONED AMOUNT (Rs.)
324)	40S_BE_1290	REGENERATIVE STEERING OPERATED DIRECTIONAL HEADLIGHTS	AUTOMOBILE ENGINEERING	MRS. NISHA KRISHNAN	MR. ZAKIRALI M	7,000.00
325)	40S_BE_1292	AQUA SILENCER IN IC ENGINES, TO REDUCE EMISSIONS AND NOISE	AUTOMOBILE ENGINEERING	PROF. SUNIL PRASHANTH KUMAR S	MR. SANDEEP E	5,000.00
326)	40S_BE_0543	DESIGN & FABRICATION OF COST EFFECTIVE EQUIPMENT USING BIOFILTERS FOR THE REMOVAL OF FLUE GAS OR AUTO-EXHAUST GAS UTILIZING SOLAR ENERGY	BIOTECHNOLOGY ENGINEERING	PROF. GIRISH N. DESAI	MS. PAVITHRA V.G.	6,500.00
327)	40S_BE_0633	UCAP POWERED INSULIN PUMP	ELECTRONICS AND COMMUNICATION ENGINEERING	PROF. NISHA K.C.R , PROF. DHARMAMBAL V & PROF. ANITHA A.	MS. APARNA REVI	6,500.00
328)	40S_BE_0025	DESIGN AND OPTIMIZATION OF WATER TANKER FOR REDUCING THE SPILLAGE UNDER DYNAMIC CONDITIONS	MECHANICAL ENGINEERING	DR. M S GANESHA PRASAD, PROF. TRUPTI P WANI	MR. GOWTHAM N A	5,000.00
329)	40S_BE_0036	PORTABLE WATER TURBINE	MECHANICAL ENGINEERING	PROF. KADOLE PAVAN PRABHAKAR	MR. RAKHESH H S	5,000.00
330)	40S_BE_0037	CARBON - DI - OXIDE POWERED SOLAR DESALINATION UNIT	MECHANICAL ENGINEERING	PROF. SUJEETH SWAMI	MR. NITHIN BERCHMANS	5,000.00
331)	40S_BE_1293	IMPROVISATION OF SOLAR PORTABLE ALL TERRAIN WHEELCHAIR WITH CRANK AND SHAFT MECHANISM	MECHANICAL ENGINEERING	PROF. RONALD REAGON R	MR. A RAMESH	6,000.00

332)	40S_BE_1295	HARDNESS AND WEAR ANALYSIS OF DLC COATED AL-ALLOY PLATES WITH AND WITHOUT HEAT TREATMENT	MECHANICAL ENGINEERING	PROF. SRINATH M K, DR. M S GANESHA PRASAD	MR. ASWIN A KURUP	4,000.00
333)	40S_BE_1297	ENHANCING THE LIFE OF PORTABLE BATTERY USING FIN STRUCTURE	MECHANICAL ENGINEERING	MR. BOPANNA K D	MR. K BHANUPRAKASH SAIRAM	4,000.00



REDMI NOTE 8 PRO
AI QUAD CAMERA

2

Ref. No. 65-12/RIFD/SPDP/Policy-1/2016-17

4. The date of release of the grant by AICTE shall be taken as the date of commencement of the project. The Principal shall intimate about the receipt of the grant to AICTE. Any expenditure incurred prior to the issuance of the approval letter will not be allowed to be adjusted in the grant and if the Institution/ University do not take the project within 6 months of the receipt of the grant, the approval shall ipso facto lapse.
5. Each project sanctioned by AICTE is assigned a specific Ref. No. given on the pre-page. All correspondences related to the project must contain this number along with year of sanction of the project; failing which correspondence will not be entertained.
6. The accounts of the grantee which are liable to be audited by the Council or Comptroller and Audited General of India or by any Officer designated for the purpose.
7. The institute/University shall not charge any overheads on this project and will provide all the administrative support for completion of the project.
8. The grantee shall utilize grants on only approved items of expenditure (list enclosed). However in case the grantee wishes to recast the project, approval of the Council must be obtained for the revised item of expenditure and they will maintain proper accounts of the expenditure as per the norms/procedures of AICTE/Government of India.
9. The assets acquired wholly or substantially out of All India Council for Technical Education's grant shall not be disposed or encumbered or utilize for the purpose other than those for which the Grant was given without proper sanction of the All India Council for Technical Education and should at any time the institution cease to function, such assets shall revert to the All India Council for Technical Education.
10. The grantee shall maintain an audited record of assets acquired wholly or substantially out of the grant-in-aid and a register or assets shall be maintained by the Institute in the prescribed form i.e. GFR-19.
11. The Amount of interest accrued on the grant should be treated as part of the grant to be utilized for that particular project. However, the interest amount accrued along with grant disbursed should not exceed the total grant sanctioned for the project. The Institute receiving the grant should reflect the same in the audited statement of accounts/ Utilization Certificate and may either refund the interest amount to AICTE or AICTE should adjust the same in the next installment of grant before releasing.
12. Since the duration of the project is for three (03) years, 25% of the sanctioned fund will be released in equal installments during the next two years after receipt of feedback, attendance, utilization certificate (UC) and other supporting documents.
13. The Annual Progress Report in the prescribed format along with Statement of Expenditure and Audited Utilization Certificate shall be submitted to AICTE not later than one month after completion.
14. Project Completion Report (PCR) in the prescribed format along with the Audited Statement of Expenditure indicating expenditure incurred in the total duration of the project in the prescribed format, utilization in the format and GFR-19 shall be submitted to the Council.
15. The Utilization Certificate (UC) supported by Audited Statement of Expenditure to the effect that the grant has been utilized for the purpose for which it has been sanctioned shall be furnished to the All India Council for Technical Education immediately after completion of the project. It should contain the head-wise break up of expenditure made from the grant-in-aid provided by the Council.
16. The grantee shall follow the terms and conditions of Skill and Personality Development Programme Centre for SC/ST Students (SPDP) as laid down by the council from time to time.

Contd...3/-

Ref. No. 65-12/RIFD/SPDP/Policy-1/2016-17

17. The Grantee shall fully implement the official language policy of Union Government and comply with the official language Act, 1963 and official language (use of official purposes of the Union Rules, 1976 etc.)
18. The University / Institute receiving grant under SPDP is expected to put up a plaque at the main entrance of the Lab/Department, which has been modernized using the grant. All the equipment procured through the project should be superscribed with AICTE project file number.
19. The funds to the extent are available under the scheme.
20. The sanction issues in exercise of the powers delegated to the Council. It is also certified that grant-in-aid is being released in conformity with the Rules and Regulation of the scheme.

Yours Sincerely,

(Dileep N. Malkhede) 18/5/17
Advisor (RIFD)

Copy forwarded for information and necessary action to:

1. ✓ The Principal,
NEW HORIZON COLLEGE OF ENGINEERING
(E&T), RING ROAD, NEAR MARATHALLI,
BELLANDUR POST, KADUBHISANAHALLI,
BANGALORE URBAN, BANGALORE-560103,
Karnataka
2. Dr. SHEELAN MISRA,
Dept. of Management
NEW HORIZON COLLEGE OF ENGINEERING
(E&T), RING ROAD, NEAR MARATHALLI,
BELLANDUR POST, KADUBHISANAHALLI,
BANGALORE URBAN, BANGALORE-560103,
Karnataka
3. Office of Director General of Audit,
(Central Revenues)
AGCR Building, I.P. Estate,
New Delhi-110 002.
4. Guard File

(Dileep N. Malkhede) 18/5/17
Advisor (RIFD)

Ref. No. 9-85/RIFD/MODROB/Policy-1/2016-17

_____.2017

The Drawing and Disbursing Officer
Local

Sub: Release of Grant-in-Aid under Modernization and Removal of Obsolescence Scheme (MODROBS) for the year 2016-17 payable during the current financial year 2017-18.

Sir,

I am directed to convey the sanction of the Council for payment of Rs.1320000/- (Rupees Thirteen Lakh Twenty Thousand Only) for the year 2016-17 under the Modernization and Removal of Obsolescence Scheme (MODROBS) to New Horizon College Of Engineering (E&T), Ring Road, Near Marathalli, Bellandur Post, Kadubhisahalli-560103, Karnataka for meeting the expenditure for implementing the Scheme as per details given below:

1. Name of the Beneficiary Institution : New Horizon College Of Engineering (E&T), Ring Road, Near Marathalli, Bellandur Post, Kadubhisahalli-560103, Karnataka
2. Chief Coordinator's Name & Deptt. : Dr. Pratima Khandelwal, Deptt. Of Biotechnology
3. Title of the Project : Modernization of Molecular Biology & Genetic Engineering Lab
4. Grant-in-aid Sanctioned : Rs.1650000/- [Rs.1358824 /- for non-recurring and Rs.291176 /- for recurring expenditure]
(80% in advance and 20% as reimbursement on submission of UC and other related documents)
5. Amount to be released : Rs. 1320000/-
6. Approved Duration (in years) : 2 Year

1. The sanctioned grant-in-aid is debitible to the major Head 601.4.a MODROBS grant and is valid for payment during the financial year 2016-17.
2. The grant-in-aid of the grant shall be drawn by the Drawing and Disbursing Officer (DDO), All India Council for Technical Education, New Delhi on the Grants-in-aid bill and shall be disbursed to and credited to the account of The Principal / Director / Registrar New Horizon College Of Engineering (E&T), Ring Road, Near Marathalli, Bellandur Post, Kadubhisahalli-560103, Karnataka.
3. The Institute is requested to verify the correctness of the under mention bank account/ RTGD submitted by them along with the proposals, in which the grant is being released. In case of any omission the same should be reported to AICTE immediately along with refund of entire grant.

Bank Name	Bank Branch and address	Account Holder's Name	Account Number	Type of Account	IFSC Code	Type of Institution	Institution's PAN No.
Indian Bank	NHCE extension, Ring road, Near Marathahalli, Kadubisanahalli, Bangalore	New Horizon College Of Engineering	484700078	Saving Account	IDIB000N112	Unaided Private	AAATN3061E

4. The date of release of the grant by AICTE shall be taken as the date of commencement of the project. The Principal / Director / Registrar shall intimate about the receipt of the grant to AICTE. Any Expenditure incurred prior to the issuance of the approval letter will not be allowed to be adjusted in the grant and if the Institution / University do not take the project work within one month of the receipt of the grant, the approval shall ipso facto lapse.
5. Each project sanctioned by AICTE is assigned a specific Ref. No. given on the pre-page. All correspondences related to the project must contain this number along with year of sanction of the project; failing which correspondence will not be entertained.
6. The accounts of the grantee which are liable to be audited by the Council or Comptroller and Audited General of India or by any Officer designated for the purpose.
7. The institute/University shall not charge any overheads on this project and will provide all the administrative support for completion of the project.

Contd...2/-

cc. to Director AICTE for kind information.

3. The grantee shall utilize grants on only approved items of expenditure (list enclosed). However, in case the grantee wishes to recast the project, approval of the Council must be obtained for the revised item of expenditure and they will maintain proper accounts of the expenditure as per the norms/procedures of AICTE/Government of India.
9. The assets acquired wholly or substantially out of All India Council for Technical Education's grant shall not be disposed or encumbered or utilize for the purpose other than those for which the Grant was given without proper sanction of the All India Council for Technical Education and should at any time the institution cease to function, such assets shall revert to the All India Council for Technical Education.
10. The grantee shall maintain an audited record of assets acquired wholly or substantially out of the grant-in-aid and a register or assets shall be maintained by the Institute in the prescribed form i.e. GFR-19.
11. The amount of interest accrued on the grant should be treated as part of the grant to be utilized for that particular project. However, the interest amount accrued along with grant disbursed should not exceed the total grant sanctioned for the project. The Institute receiving the grant should reflect the same in the audited statement of accounts/ utilization certificate and may either refund the interest amount to AICTE or AICTE should adjust the same in the next installment of grant before releasing.
12. Since the duration of the project is for two years, the request for reimbursement of 20% of remaining amount shall be made with UC and other related documents in such a way that the entire project is completed in the prescribed period of two years.
13. The Annual Progress Report in the prescribed format along with Statement of Expenditure and Audited Utilization Certificate shall be submitted to AICTE not later than one month after completion.
14. Project Completion Report (PCR) in the prescribed format along with the Audited Statement of Expenditure indicating expenditure incurred in the total duration of the project in the prescribed format, utilization in the format and GFR-19 shall be submitted to the Council.
15. The Utilization Certificate (UC) supported by Audited Statement of Expenditure to the effect that the grant has been utilized for the purpose for which it has been sanctioned shall be furnished to the All India Council for Technical Education immediately after completion of the project. It should contain the head-wise break up of expenditure made from the grant-in-aid provided by the Council.
16. The grantee shall follow the terms and conditions of Modernization and Removal of Obsolescence (MODROBS) as laid down in the scheme details under AICTE AQIS 2016-17.
17. The Grantee shall fully implement the official language policy of Union Government and comply with the official language Act, 1963, and official language (use of official purposes of the Union Rules, 1976 etc.)
18. The University / Institute receiving grant under MODROB is expected to put up a plaque at the main entrance of the Lab/Department, which has been modernized using the grant. All the equipment procured through the project should be super scribed with AICTE project file number.
19. The funds to the extent are available under the scheme.
20. The sanction issues in exercise of the powers delegated to the Council. It is also certified that grant-in-aid is being released in conformity with the Rules and Regulation of the scheme.

Yours Sincerely,

(Dileep N. Malkhede)
Advisor (RIFD)

08 SEP 2017

Copy forwarded for information and necessary action to:

1. ✓ The Principal / Director / Registrar,
New Horizon College Of Engineering (E&T), Ring Road, Near
Marathalli, Bellandur Post, Kadubhisanahalli-560103, Karnataka
2. Dr. Pratima Khandelwal,
Deptt Of Biotechnology
New Horizon College Of Engineering (E&T), Ring Road, Near
Marathalli, Bellandur Post, Kadubhisanahalli-560103, Karnataka
3. Office of Director General of Audit,
General Revenues, AGCR Building, I.P. Estate,
New Delhi-110 002.
4. Guard File



TSC Technologies Pvt. Ltd.
W: tsctech.in M: +91 9741896297
E: operations@tsctech.in

CIN: U93000KA2020PTC132954
GSTIN: 29AAHCT7891C1ZV
PAN/IEC: AAHCT7891C

Ref: UNITYsat/CubeSat/OBC/001

16 August 2016

To

The Principal (Attention to Prof & HoD, Dept of CSE)
New Horizon College of Engineering (NHCE)
Outer Ring Road, Kadubesnahalli,
BANGALORE, KARNATAKA

**Design of OBC for CubeSat and Programming and Validation-06 Months (2016-17)-Project
Cost: Rs. 3,00,000/- (Rupees Three Lakhs Only)**

Dear Professor,

SUB: Sanction of Grant-in-Aid-Joint Development- Design of OBC for CubeSat and Programming and Validation- 06 Months (2016-17)- Rs.3,00,000/-Reg.

REF: Your Project Proposal in Response to Announcement of Opportunity-Our Interactions/On-line Meetings/MoU Signed with Your Institution on 05 April 2016

Under the powers vested with Programme Office for the UNITYsat Programme as per the TSC-ITCA-CSPD Consortium which has signed MoU on 05 April 2016 and subsequent Announcement of Opportunity issued, I am directed to convey the sanction of the following project for the year 2016-17:

Title of the Project: "**Design of OBC for PocketQube Satellite and Programming and Validation**"

Amount: **Rs. 3.0 Lakhs as Grant-in-Aid**

Duration: **06 Months**

AY/FY: **2016-17**

Terms and Conditions of Sanction of Grant-in-Aid

1. Funds for second installment will be released on satisfactory progress and submission of six month progress report by PI to the Programme Office and based on recommendation with due approval of competent authority.
2. Statement of accounts and utilization certificate duly certified by the executive financial authority of the Institution is also required to be submitted along with the annual report. Excess expenditure, beyond the sanctioned amount, shall be responsibility of grantee institution.
3. The duration of the project is TWELVE MONTHS (One Year) with review after six months! The date of receipt of the grant would be reckoned as the commencement date of the project which has to be intimated to the Programme Office without any ambiguity.
4. A separate account for the grant would be maintained by New Horizon College of Engineering and any interest earned thereon, if any, would accrue to UNITYsat Programme.
5. Unspent balance, on completion of the project should be sent by the grantee institution through a RTGS/Cheque/Draft in the name of TSC Technologies P Ltd, Bangalore for doing the needful.
6. A list of inventory of equipment purchased out of the Programme grant shall be intimated year-wise, along with its cost and source of procurement to the Programme Office.
7. On completion of the project, the grantee institution would forward the consolidated list with request, if any, for the retention of any equipment for another project or in-house R&D, with due recommendations of their executive authority and the concerned panel.

8. In case of any joint publications of Technical Research Papers related to this project as a part/outcome of the research works shall have the mentioning/acknowledgement of consortium which has granted the matching grant for the project appropriately.
9. A Closure Report alongwith copies of technical report may be submitted within sixty days of completion of project alongwith Statement-2 (Statement of Expenditure) and Statement -3 (Utilization Certificate) as per the Annexure III of Grants-in-aids rules duly audited from the Audit Authority of Institution signed in ink in duplicate.
10. TSC Technologies P Ltd, Bangalore will make disbursement of money/equivalent in kind as sanctioned.

With Warm Regards,

Yours Sincerely,



(NIKHIL RIYAZ)

Director

TSC Technologies Private Limited

M: +91 97418 96297

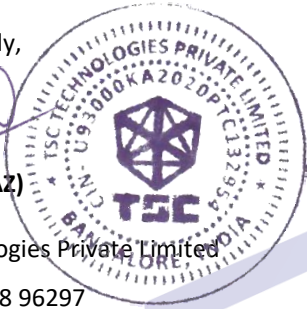

Copy to

- a) Programme Director, UNITYsat Programme Office, Bangalore
- b) President, Indian Technology Congress Association
- c) Head, Committee for Space Programme Development, Serbia
- d) Convener, 75 Students' Satellites Consortium: Mission 2022
- e) Professor and HoD, NHCE, Bangalore





UNISEC Global, HQ at Japan

<http://www.unisec-global.org/localchapters.html>

Under Association of Indian Local Chapters

University Space Engineering Consortium (UNISEC)-INDIA

Secretariat, 4th Floor, #3, First Main, BDA Layout, Kodihalli, HAL 2nd Stage, Bengaluru – 560008, Karnataka, India. Ph: 080 6559 2501; 080 4850 8380; Website: www.unisec-india.in

Ref: SiCS-B/Sat Bus/JD-Indo-Israel/001

23 September 2016

To

The Principal (*Attention to Prof & HoD, Dept of Mech/CSE/ECE*)

New Horizon College of Engineering (NHCE)

Outer Ring Road, Kadubesnahalli,

BANGALORE, KARNATAKA

**Development of “Single Card Satellite-Bus (SiCS-B)”: 10 cm x 10 cm
(Timeline: 30 Months). Indo-Israel Joint Development
Partnering Funding Agencies: ITCA-TMISat, UNISEC India, DRL, TSC P Ltd**

Dear Professor,

**SUB: Sanction of Grant-in-Aid-Joint Development- Development of “Single Card Satellite-Bus (SiCS-B)”:
10 cm x 10 cm (Timeline: 30 Months). Indo-Israel Joint Development- 30 Months (2016-17 to
2017-18)-Rs.15,00,000/-Reg.**

**REF: Your Project Proposal in Response to Announcement of Opportunity-Our Interactions/On-line
Meetings/MoU Signed with Your Institution on 05 April 2016**

Under the powers vested with Programme Office for the Indo-Israel Joint Development Programme as per the ITCA-TMISat-UNISEC India-DRL-TSC Consortium which has signed MoU on 05 April 2016 and subsequent Announcement of Opportunity issued,

I am directed to convey the sanction of the following project for the respective years from 2016-17 to 2017-18:

2016-17 (Project Split-up Among Departments)

Dept. Mech: Design and Development of Satellite Monolithic Structure, Machining- Prototype: **Rs. 1,50,000/-**

Dept. CSE: On Board Computer (OBC), Coding and Programming Responsibilities: **Rs. 5,00,000/-**

2017-18 (Project Split-up Among Departments)

Dept. Mech: Design and Development of Satellite Monolithic Structure, Machining, Orbital Mechanics- Calculation-Simulation- Phase 1: **Rs. 3,00,000/-**

Dept. CSE: On Board Computer (OBC), Coding and Programming Responsibilities: **Rs. 5,00,000/-**

Overall Contingencies, Travel, Overhead Charges and Miscellaneous Expenditures: **Rs. 50,000/-**

Terms and Conditions of Sanction of Grant-in-Aid

1. Funds for second installment will be released on satisfactory progress and submission of six month progress report by PI to the Programme Office and based on recommendation with due approval of competent authority.

2. Statement of accounts and utilization certificate duly certified by the executive financial authority of the Institution is also required to be submitted along with the annual report. Excess expenditure, beyond the sanctioned amount, shall be responsibility of grantee institution.
3. The duration of the project is THIRTY MONTHS (2.5 Years) with review after six months! The date of receipt of the grant would be reckoned as the commencement date of the project which has to be intimated to the Programme Office without any ambiguity.
4. A separate account for the grant would be maintained by New Horizon College of Engineering and any interest earned thereon, if any, would accrue to SiCS-B Programme.
5. Unspent balance, on completion of the project should be sent by the grantee institution through a RTGS/Cheque/Draft/in Kind in the name of UNISEC India/TMISat/ITCA/TSC Technologies P Ltd, Bangalore for doing the needful.
6. A list of inventory of equipment purchased out of the Programme grant shall be intimated year-wise, along with its cost and source of procurement to the Programme Office.
7. On completion of the project, the grantee institution would forward the consolidated list with request, if any, for the retention of any equipment for another project or in-house R&D, with due recommendations of their executive authority and the concerned panel.
8. In case of any joint publications of Technical Research Papers related to this project as a part/outcome of the research works shall have the mentioning/acknowledgement of consortium which has granted the matching grant for the project appropriately.
9. A Closure Report alongwith copies of technical report may be submitted within sixty days of completion of project alongwith Statement-2 (Statement of Expenditure) and Statement -3 (Utilization Certificate) as per the Annexure III of Grants-in-aids rules duly audited from the Audit Authority of Institution signed in ink in duplicate.
10. UNISEC India/TMISat/ITCA/TSC Technologies P Ltd, Bangalore will make disbursement of money/equivalent in kind as sanctioned.

With Warm Regards,

Truly Yours,



(Dr. L. V. MURALIKRISHNA REDDY)

President, UNISEC India

President, 75 Students' Satellites Consortium: Mission 2022

Copy to

- a) Programme Director, Indo-Israel Joint Development Programme Office, Bangalore
- b) President, Indian Technology Congress Association
- c) Head, TMISat, Isarel
- d) Convener, 75 Students' Satellites Consortium: Mission 2022
- e) Professor and HoDs, Mech/CSE/ECE, NHCE, Bangalore

Payee

स्टेट बैंक ऑफ मैसूर
STATE BANK OF MYSORE

MULTICITY CHEQUE - SAVINGS ACCOUNT
IFSC Code: SBMY0040463 (Ph.No: 080-26718759)

Valid for three months from the date of instrument

16042015
D D M M Y Y Y Y

बनशंकरा II स्टेज शाखा (40463) बेंगलूर महाराष्ट्र - 560070
BANASHANKARI II STAGE BRANCH (40463), BANGALORE - 560070

PAY The Principal, New Horizon College of Engineering,

Bangalore
या धारक को OR BEARER

RUPEES रुपये Ten Lakhs Only

₹ 10,00,000/-

A/c. No. 64110830474

MANAGING DIRECTOR, KARNATAKA SCIENCE AND TECHNOLOGY PROMOTION SOCIETY

CBS BRANCH

Payable at par at all branches of State Bank of Mysore
Multicity cheque is payable upto a maximum of Rs. 500000/-

Please sign above

②
① 74 33 33 560006004: 003 104 3 1

To

The Registrar

For your kind information

Mayur

9/5/2015



GOVERNMENT OF KARNATAKA

Vision Group on Science and Technology

Department of Information Technology, Biotechnology and Science & Technology
Karnataka Government Secretariat, Room No.702, 7th Floor, 4th Gate, M. S. Building,
Dr. Ambedkar Veedhi, Bangalore-560 001, Phone: 080-2203 2013
E-mail: visiongroup.st@gmail.com

Website: www.vgst.in

Dr. S. Ananth Raj
Consultant

No.VGST/CISEE/GRD-189/2015-16

May 6, 2015

The Principal,
New Horizon College of Engineering,
Ring road, Bellandur Post, Marathalli,
Bangalore - 560 103

Dear Sir/Madam,

Greetings from Vision Group on Science and Technology (VGST)

Sub: Release of III & final instalment of VGST grant and further submission of
PART A of GRD (Budget Estimate) to VGST.

As you are aware that the VGST grant has been awarded to your institution in previous years. The details of the release of this instalment of VGST grant is indicated in the enclosed K-Steps letter.

I am herewith enclosing a crossed cheque of Rs.10,00,000/- (Ten lakhs only) vide cheque No.741313 dated 16.04.2015. Kindly acknowledge the receipt of this grant in the enclosed format. A book -Grant Related Document (GRD) is also enclosed.

The VGST Programme Co-ordinator is requested to make necessary entries in the "PART -A of GRD - Book" (enclosed) and required to submit to VGST office at the earliest (before 31st May 2015) for Budget estimate approval by VGST. The entries in the following documents is most essential.

- "Budget Estimate (Non Recurring and Recurring)"
- "Technical Specification of the equipment (TSE)- (Annexure-2)"
- "Justification for the Purchase of Equipment (JPE)- (Annexure-3)"
- "Purchase Committee (P.CMT)- (Annexure-4)"
- "Programme Co-ordinator's Declaration (PCD)- (Annexure- 5)"
- "Letter from Collaboration from Reputed Researcher/Institution/Industry (LCR)- (Annexure-6)"
- Financial Status Proforma (FSP)

Further, VGST requests the Programme Co-ordinator (PC) to visit VGST office on any convenient day before 31st May 2015 between 2.30 pm - 5.00 pm to obtain VGST's approval for the Budget estimate (both Non recurring and recurring) indicated in the PART A of GRD. The approval for the 'Budget Estimate' (both Non - Recurring and Recurring) will be given to fulfill the requirement of PC. VGST's approval for both Non-Recurring and Recurring is final. GRD book submitted to VGST after 31st May 2015 for Budget estimate approval will not be entertained.

The procurement of equipment, consumables etc., shall be initiated only after obtaining VGST's approval for the Budget Estimate (given in PART - A of GRD) (ie only after 31st May 2015).

VGST has observed that a grant of Rs.1,59,249/- is unspent in the previous release as per the AUC issued by the Auditors. Therefore Rs.1,59,249/- should be entered in the FSP provided in the GRD book and indicate Non - Recurring Budget Estimate for Rs.1,59,249/- (with interest earned till date).

PS: In the Non Recurring Budget Estimate, it is mandatory for the Grantee institution / Programme Co ordinator to procure/ include atleast one equipment more than Rs.5 lakhs which is to be procured through E-tendering process through Centre for E-governance (CEG)/Keonics. Therefore please indicate atleast one equipment more than Rs.5 lakhs in the Non Recurring Budget Estimate.

Treat this matter as most important and urgent.

Thanking you,

Yours faithfully,

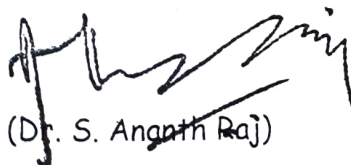
S. 
(Dr. S. Ananth Raj)

6 MAY 2015

Copy to:
Dr. M.S. Ganesh Prasad,
Professor & Head,
Dept. of Mechanical Engineering
New Horizon College of Engineering,
Ring road, Bellandur Post, Marathalli,
Bangalore - 560 103

ALL INDIA COUNCIL FOR TECHNICAL EDUCATION

4th Floor, East Tower, Bhishma Pitamah Marg, Pragati Vihar, New Delhi-110003

F.No. 4-40/RIFD/EDC/ 2013-14

Dated : 11.08.2015

To

The Drawing and Disbursing Officer
All India Council for Technical Education
7th Floor, Chanderlok Building, Janpath
New Delhi-110001

①

Sub : SANCTION ORDER for Release of 2nd installment under Entrepreneurship Development Cell (EDC) Scheme, during the financial year 2015-16.

Sir,

I am directed to convey the sanction of the Council for payment of **Rs. 1,40,000/-** (Rupees One Lakh Forty Thousands only) i.e. 2nd installment under the Scheme of EDC as Grant-in-aid for meeting the expenditure under recurring head, for implementing the Scheme to the Coilege during the financial year 2015-16,, as per details given below :

Name and address of the Institution : **New Horizon College of Engineering**,
Ring Road, Near Marathalli, Bellandur Post, Kadubhisanaahalli,
Bangalore Urban, Karnataka-560103

Name of Chief Coordinator : Dr. Sheelan Misra

Total amount of Grant Sanctioned : **Rs.4,55,000/-** [Rs.1,75,000/- for non-recurring+Rs.2,80,000/- for recurring expenditure.

Amount to be released : **Rs.1,40,000/-** i.e. 2nd & final installment of grant-in-aid for meeting recurring expenditure]

1. The sanctioned grant-in-aid is debitable to the major head: 601.5.a (EDC) and is valid for payment during the financial year 2015-16
2. The grant-in-aid of the grant shall be drawn by the Drawing and Disbursing Officer (DDO), All India Council for Technical Education (AICTE), New Delhi, on the basis of Grants-in-aid bill and shall be disbursed to and credited to the Registrar / Director / Principal, through E-Payment system.
3. The date of release of the grant by AICTE shall be taken as the date of commencement of the project. The Registrar/Director/Principal shall intimate about the receipt of the grant to AICTE.
4. **The project sanctioned by the AICTE is assigned a specific file number which is mentioned above. All correspondence addressed to AICTE regarding the project must quote this number along with year of sanction of the project otherwise the correspondence will not be entertained.**
5. The Institute / College / University shall not charge any overheads on this project and will provide all the administrative support for completion of the project.
6. The University / College / Institute shall utilize grant only on approved items of expenditure and maintain proper accounts of the expenditure as per the norms/procedures of AICTE/Govt. of India.
7. The assets acquired wholly or substantially out of All India Council for Technical Education's grants shall not be disposed or encumbered or utilized for purposes other than those for which the Grant was given, without proper sanction of the All India Council for Technical Education and should at any time the Institution ceased to function, such assets shall revert to the All India Council for Technical Education.
8. The University / College / Institute shall maintain an audited record of assets acquired wholly or substantially out of the grant and a register of assets shall be maintained by the Institute in the prescribed form, i.e. General Financial Rules (GFR)-19.

Contd....2/-

12.8.15

KARNATAKA STATE COUNCIL FOR SCIENCE AND TECHNOLOGY
Indian Institute of Science Campus, Bengaluru - 560012

LIST OF B.E. PROJECTS SANCTIONED UNDER 39th SERIES OF STUDENT PROJECT PROGRAMME : 2015-2016

71) NEW HORIZON COLLEGE OF ENGINEERING, BENGALURU

Sl No.	Project proposal Ref. No.	TITLE OF THE PROJECT	BRANCH	NAME OF THE GUIDE/S	STUDENT1 & TEAM LEADER	SANCTIONED AMOUNT (Rs.)
295.	39S_BE_0028	STUDIES ON METAL POWDER COATING ON 3-D PRINTED COMPONENTS	MECHANICAL ENGINEERING	MR. SRINATH M.K	MR. VINEET YADAV	4,000.00
296.	39S_BE_0029	MULTI-PURPOSE COMPACT SOLAR FRUIT DRYER	MECHANICAL ENGINEERING	DR. M S GANESHA PRASAD & MR. RONALD REAGON R	MR. GOWTHAM R	4,000.00
297.	39S_BE_0032	DEVELOPMENT OF HYDROCYCLONE FOR FILTRATION OF METAL WORKING FLUIDS	MECHANICAL ENGINEERING	DR. M S GANESHA PRASAD & PROF. PUNEETH H V	MR. GIRISH H S	4,000.00
298.	39S_BE_0034	GENERATION OF POWER FROM FLUIDS FLOWING THROUGH PIPES	MECHANICAL ENGINEERING	PROF. RAKESH C	MR. ARUN R	4,000.00
299.	39S_BE_0035	MECHANICAL DESIGN OF A ROBOTIC ARM EXOSKELETON FOR ARM REHABILITATION	MECHANICAL ENGINEERING	PROF. RAKESH C	MR. S.M. DANISH	4,000.00
300.	39S_BE_0038	SMART TECHNOLOGY IN WEED REMOVAL FROM LAKES	MECHANICAL ENGINEERING	PROF. RAKESH C	MR. GAUTAM JANARSHAN	5,000.00
301.	39S_BE_0039	WASTE SEGREGATION USING ACTUATORS	MECHANICAL ENGINEERING	PROF. VIJAY B R	MR. PREETHAM M J	5,000.00
302.	39S_BE_0040	STUDIES IN REUSABILITY OF POLYMER PRODUCTS INTO USEFUL FUEL	MECHANICAL ENGINEERING	DR. M S GANESHA PRASAD & PROF. RAKESH	MR. SIDDARTH DINESH	4,000.00
303.	39S_BE_1061	FORMULATION AND CHARACTERIZATION OF METHYL CELLULOSE USED IN PAINTS FOR FIRE RETARDANT	BIOTECHNOLOGY ENGINEERING	MR. K.R.DASEGOWDA	MR. ADITYA.S	4,000.00



**KARNATAKA STATE COUNCIL FOR
SCIENCE AND TECHNOLOGY**
Indian Institute of Science Campus, Bengaluru



**COMPENDIUM OF 39TH SERIES STUDENT
PROJECT PROGRAMME (Biofuel Projects)**

SUPPORTED BY

KARNATAKA STATE BIOENERGY DEVELOPMENT BOARD
DEPARTMENT OF RURAL DEVELOPMENT AND PANCHAYAT RAJ, GOVERNMENT OF KARNATAKA

2015-2016

The model was validated by conducting experiments at optimum conditions and comparing it with predicted values from the model. The experimental value of concentration of reducing sugar was found to be similar to the predicted values of the model giving an R-square value of 0.97.

* ~ * ~ *

5. Design and fabrication of economically viable hybrid Photobioreactor (closed bobble column) prototype for cultivation of elite Microalgae for enhanced lipids (biodiesel) Yield

PROJECT REFERENCE NO.: 39S_B_BE_005

COLLEGE : NEW HORIZON COLLEGE OF ENGINEERING

BRANCH : BIOTECHNOLOGY

GUIDES : MR. R.S. UPENDRA, DR. PRATIMA KHANDELWAL

STUDENTS : MS. AAKRUTI RUIA

MS. AMULYA GRACE

MS. ANJALI TIWARI

Introduction / background:

The present era relies on fossil fuel combustion to produce their fuels. Fossil fuels are non-renewable sources of energy, and are rapidly depleting. The main source of fuels is by coal at an average 49% of fuels are obtained from burning coal, studies estimated that by the year 2051 coal will be depleted (**Bauer et al., 2015**). However, fossil fuels combustion leads to the emission of carbon in the environment and the increasing amount of carbon is leading to global warming, world is now looking for new ways to produce fuels in an eco-friendly manner. Biofuels are such one alternative, can be produced by utilizing organic matter derived from plants, animals or microorganisms (**Rudolf, 1926**). Biofuels are a key factor that can reduce the global warming issue and also meet the rising demand of fuels. Biofuels have been researched upon for a long time and have been modified, thus there are four generations of biofuels (Table 1). Fourth generation which are most researched upon and utilized microalgae for lipid subsequently converted in to biofuels (**Yafei et al., 2014**).

Keywords: Microalgae, renewable energy Hybrid photobioreactor, Lipid yield, FTIR.

Table 1: Generations of Biofuels

GENERATION	TYPE
1 st	Agricultural food crops based (<i>e.g.</i> Wheat, sugar <i>etc</i>)
2 nd	Agricultural non-food crops (<i>e.g.</i> Wood <i>etc</i>)
3 rd	Algal species used for oil production
4 th	Microalgae for lipid based biofuels extraction

Objectives:

Microalgae are unicellular photosynthetic organisms that assimilate lipids, which can be converted in to Biofuels. Microalgae help to mitigate carbon dioxide, because of their photosynthetic properties and utilize it to produce lipids. Microalgae biomass is a zero waste generation, as every part of the biomass is utilized to generate other value added

products such as Bioethanol, Nutraceuticals, Biofertilizer, Biodiesel and Gasoline (Clayton *et.al*, 2010). Biofuels are being adapted in various countries as alternative fuels (Herve *et.al*, 2011). Scanty research was documented on using Microalgae as feedstock for Biodiesel production. Photobioreactor (PBR) is specially designed for effective cultivation of microalgae, however hybrid PBR have been meagerly researched. Scanty research has been done on tubular type PBR and the various light source tested being of less impact on the growth of microalgae. With the lacunae discussed the present investigation aimed in following objectives.

1. Design and fabrication of hybrid photobioreactor (combing flat plate and tubular type of photobioreactor).
2. Mass cultivation of newly isolated species (*Chlorella rotunda*) in the indigenously designed photobioreactor.
3. To enhance the yield of biomass and lipid content for biodiesel and other value added products

Methodology:

The present study designed a hybrid PBR (flat plate and tubular) based on both batch and continuous kinetic modules, considering the different design dimensions i.e height, breath, width, diameter of tubular column, surface area and volume Fig.1.

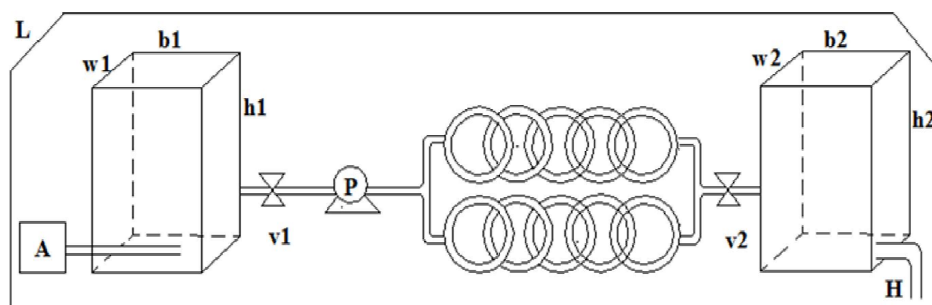

Fig 1: CAED design of Continuous Hybrid Photobioreactor. Dimensions: A: Aerator, b1, b2: breath, w1, w2-width, h1, h2: height, v1, v2: valves, H: harvest, L: LED light.

Study utilized LED as the source of artificial blue light to support the growth of microalgae. Initially preserved microalgae culture was revived on BBM plate. The purity and metabolic stability of the revived microalgae was accessed through morphological and microscopic (both light and SEM) observations. The designed and fabricated hybrid PBR was tested for microalgae cultures, in both batch and continuous cultivation process (Turbidostat). Optimized modified Bolds Basal media (BBM) (Mounisha *et.al*, 2015) was used in the present investigation. Further the study compared the growth of microalgae and its biomass yield @ both optimal (PBR cultures) and flask cultures conditions. Further growth kinetics of the microalgae was studied measuring the absorbance at visible range (550nm). Finally lipid estimation was carried out considering certain time interval for both the cultures (PBR and Flask) colorimetrically and final confirmation of the lipids was down using FTIR analysis.

Results and Conclusions:

The results reported that indigenously designed PBR supported exponential growth, and was reported due to the provision of optimal growth conditions provided by the PBR compare to the flask cultures Fig.2.



Fig. 2: Designed and fabricated PBR with LED light source.

The molecular and phylogenetic analysis revealed that the *microalgae spp* was found to be *Chlorella rotunda*. The lipid estimation reported the lipid concentration 2.4 mg/ml for PBR cultures, was 4 folds higher than the flask cultures (0.24 mg/ml) Fig.3. The doubling time measured was reduced from 63 hrs in shaken flask cultures to 2.88 hrs in first batch PBR. A second batch was done to further reduce the doubling time in PBR cultures providing carbon dioxide a source. In the second batch, doubling time was reduced to 1.5 hrs and the lipid content increased further to 3.7 mg/ml which is 1.5 folds higher than the first batch (2.5mg/ml).

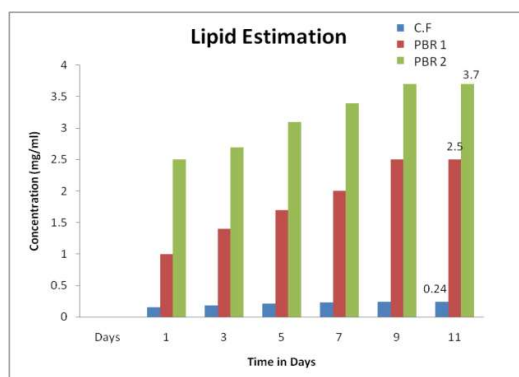

Fig 3: Comparison of lipid yield under optimized and un-optimized conditions

The preset study concludes by reporting the designed and fabricated PBR supported for the mass cultivation of microalgae *Chlorella rotunda*.

Scope for future work: The pilot plant studies need to be carried out for the suggested PBR design.

* ~ * ~ *



Registered Office:
No. 6, 4th Floor, Vishaal De Mall, #31, Gokhale Road, Chinna Chokkikulam,
Madurai - 625 002, INDIA
Phone: 0452-4350022M: +91 9566776675
E-mail: tmsri@yahoo.co.in
Web: www.7Dfuncorner.com

S. SRIDHAR, M.Com
Managing Partner

To

2th April 2016

Dr. Sanjay Jain

Head of the Department, Department of ECE,
New Horizon College of Engineering,
Bangalore-103

Dear Professor,

SUB: Project Approval and Fund release for "Motion File Extraction".

With reference to our earlier mails, herewith, we are expressing our willingness to accept your project proposal and we are confirming total payment of amount **Rupees Three Lakhs Twenty Thousand** (Rs. 3,20,000/-), vide Cheque No. 050527 dated 02.04.2016. The fund shall be used for the project "**Motion File Extraction**" only. We request your cooperation to complete the project within next one year.

Kindly acknowledge the receipt of this letter by email immediately.

Thanking you,

With Regards,

A handwritten signature in black ink, appearing to be 'S. Sridhar', written in a cursive style.

S. SRIDHAR
Managing Partner
7D+ FUN CORNER

Cc To: The Principal and Dean (R&D), NHCE